



KingsWay School

To be a Christian community of learning that nurtures young people towards their full potential as servant leaders in the Kingdom of God

Senior School 2025

Options Handbook

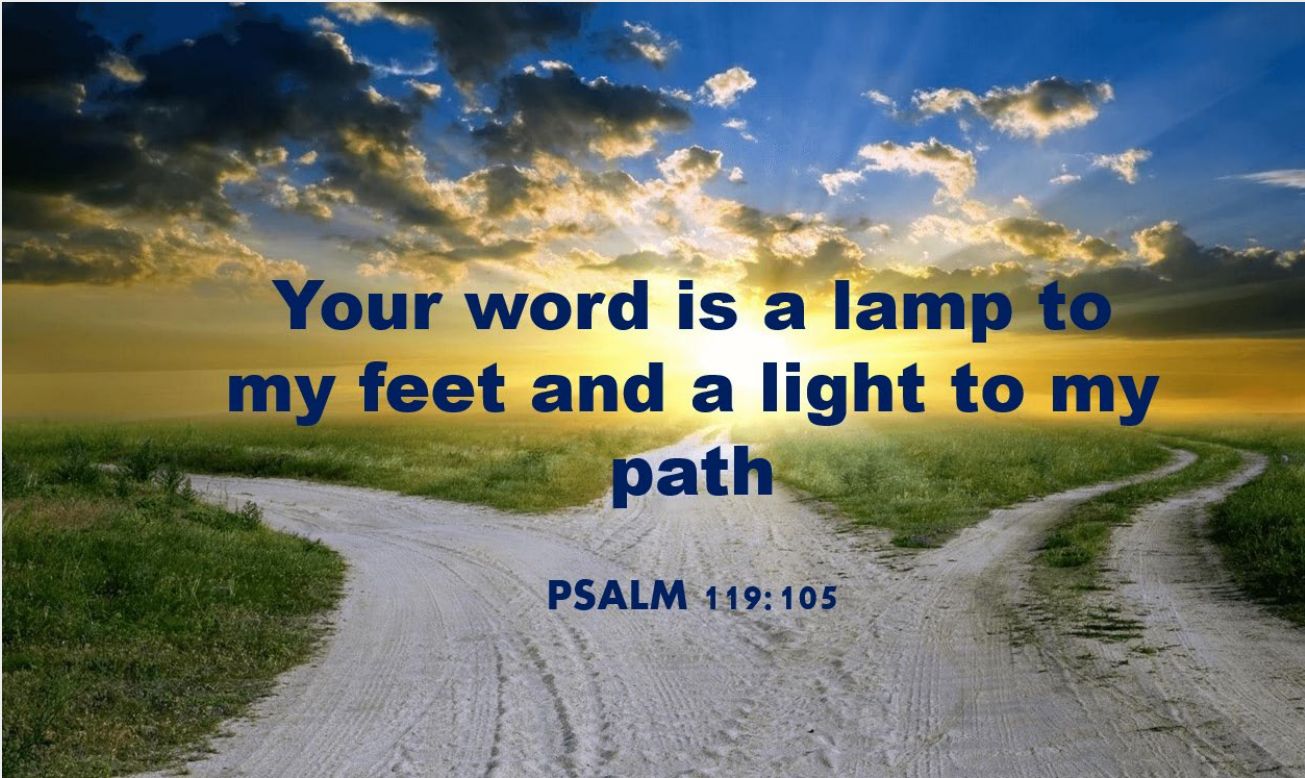

COURSES

CHOICES

FUTURE

CAREERS

Contents

People to Contact – course selection & future pathways 4

Message from the Principal..... 5

Mission Statement..... 6

Vision..... 6

Message from Head of Senior School..... 6

A Guide to NCEA 7

How to select options for next year using KAMAR..... 9

Subject Selection - Timeline 10

University Entrance..... 10

University Approved Subjects offered by Kingsway School 11

Exceptions By Application 12

Costs..... 13

Pathways Planner 14

Year 11 Courses - 2025..... 16

Level 2 Courses - 2025 27

Level 3 Courses - 2025 44

Faculty Pathways	62
Arts Faculty.....	62
Biblical Studies Faculty	62
Business Faculty	63
English and Languages Faculty	64
Mathematics Faculty	65
Physical Education and Hauora Faculty	66
Science Faculty	67
Social Sciences Faculty	67
Technology Faculty.....	68
A Guide to NCEA Assessment Procedures.....	69

People to Contact – course selection & future pathways

Head of Senior School	D Bennett	daniel.bennett@kingsway.school.nz
Assistant Head of Senior School	C Thomson	colin.thomson@kingsway.school.nz
Assistant Head of Senior School	C Trebilco	claire.trebilco@kingsway.school.nz
Assistant Head of Senior School	M Harris	matt.harris@kingsway.school.nz
Head of Careers and Pathways	C Perrow	cherie.perrow@kingsway.school.nz
Head of Faculty: Arts	S Catterall	sophie.catterall@kingsway.school.nz
Head of Faculty: Business	B Cahill	ben.cahill@kingsway.school.nz
Head of Faculty: English & Languages	C Wells	christine.wells@kingsway.school.nz
Head of Faculty: Mathematics	J Moynihan	julie.moynihan@kingsway.school.nz
Head of Faculty: Pathways	C Perrow	cherie.perrow@kingsway.school.nz
Head of Faculty: PE/Hauora	J Debenham	james.debenham@kingsway.school.nz
Head of Faculty: Science	J Bellingham	james.bellingham@kingsway.school.nz
Head of Faculty: Social Sciences	J Forrest	james.forrest@kingsway.school.nz
Head of Faculty: Biblical Studies	S Hawkins	simeon.hawkins@kingsway.school.nz
Head of Faculty: Technology	To be confirmed	
Dean – Year 11 and 13 Girls	C Nortje	cecile.nortje@kingsway.school.nz
Dean – Year 11 and 13 Boys	J Price	jonathan.price@kingsway.school.nz
Dean – Year 12 and 13 Girls	H Woolley	hannah.woolley@kingsway.school.nz
Dean – Year 12 and 13 Boys	G Robertson	gideon.robertson@kingsway.school.nz
Principal's Nominee (NCEA queries)		principalsnominee@kingsway.school.nz

[Return to Contents](#)

Message from the Principal

This booklet provides the information necessary for students and parents to make informed decisions regarding subject choices for 2025.

Some special features of our Senior School courses are:

- A varied range of subjects to meet the needs of individual students;
- Opportunities for multi-level study to provide flexibility for students;
- Opportunities to undertake STAR courses that lead to unit standards qualifications;
- A strong focus on the need to gain national qualifications;
- Gateway: Transition to Work Programme which provides pre-employment/apprenticeship training, career exploration and work experience opportunities.

Senior students should discuss their course ideas with parents and teachers and make choices based on sound information and advice. No student who reaches the age of 16 years in Year 11 or Year 12 should consider leaving school without first discussing other options with their parents and our staff in the Career's Department. Students should not consider leaving school at age 16 unless they have secured a job or another educational training course.

Students need to consider carefully the costs of tertiary courses and the burden of student loans. Courses offered at KingsWay School have been evaluated and adapted to deliver a quality programme that allows study through to NCEA Level 3 and Scholarship Examinations.

The staff in the Senior School at KingsWay are available to offer further assistance at any time. We encourage all students and parents to prayerfully and carefully pursue this whole process of subject selection, pathways and career options. Please contact the Head of Senior School if you have any suggestions on how KingsWay can improve or streamline this process.

Graeme Büdler
Executive Principal

[Return to Contents](#)

Mission Statement

To be a Christian community of learning that nurtures young people towards their full potential as servant leaders in the Kingdom of God.

Vision

Our vision is for students to be:

- Confident
- Connected
- Actively Involved
- Lifelong Learners

Message from Head of Senior School

While choosing subjects, we encourage you to keep the big picture in mind. God creates us all uniquely in His Image and gives us different abilities and strengths. As you discover these, you will enjoy doing the subjects that draw on these strengths. If you choose subjects based on comparisons with others or assumptions about what others think, you may find school unnecessarily challenging.

When selecting your options, please choose carefully as we have limited scope to make changes once the timetable for next year is set. Final choices will be confirmed in November and from that point, few changes can be accommodated unless there is a subject clash, subjects are unavailable, or numbers are low in certain courses. Students will still be able to pick up options in Year 11 that they have not studied in Year 10 except for Spanish and Music which have prerequisites.

We no longer offer NCEA Level 1. Year 11 students will continue to do our rigorous preparatory program that will fully prepare them for NCEA Level 2. Students who pass all five subjects at Year 11 will gain a KingsWay qualification and excellence in this program will be recognised throughout the year and at Senior School Prizegiving.

If you are not sure about your future direction yet, choose a broad range of subjects to keep your options open (including Science, Mathematics and a literacy based subject i.e. English / History).

We trust that God will lead you as you make these important decisions.

Daniel Bennett
Head of Senior School

[Return to Contents](#)

A Guide to NCEA

[Understanding NCEA](#) – an NZQA video explaining how NCEA works

[Understanding How NCEA Requirements Are Changing](#)

NCEA is an assessment system that requires students to reach a set number of credits at each level in order to achieve the qualification.

As of 2024:

- NCEA Level 2 and Level 3 have become 60-credit qualifications and require 60 credits at certificate level or above.
- To be awarded any level of NCEA, learners will need to achieve the new 20-credit co-requisite
 - Credits used towards the co-requisite cannot be used towards the 60-credit NCEA. Essentially, the number of credits required to gain each level of NCEA remains the same, with the literacy and numeracy requirements separated out into a 'one-off' co-requisite.
 - Learners will be able to meet the 20-credit co-requisite through achieving either the new standards in Literacy-Writing, Literacy-Reading, Numeracy, Te Reo Matatini, and Pāngarau or gaining 20 credits from a list of literacy and numeracy-rich standards.

Achievement Standards

Achievement standards identify the learning outcomes students must achieve. Some standards will be assessed internally by subject teachers during the year and some will be assessed by external examination at the end of the year. There are four possible grades students can be awarded: Not Achieved, Achieved, Merit or Excellence. Achievement standards are generally worth 2 to 6 credits. There are generally 17-21 credits per course.

Unit Standards

Unit standards are offered in some courses. In most cases there are only two possible grades students can be awarded, either Achieved or Not Achieved. Unit Standards count towards NCEA. They are all internally assessed.

Scholarship

Scholarship is externally assessed by performance, portfolio or examination during the NCEA external examination period. Scholarship is designed to test, extend and reward top level students. Students studying scholarship subjects must commit to extra tutorials and significant time spent in self-directed learning out of school hours. Availability of these courses depends on teachers' ability and capacity to offer these courses.

Scholarship is not a qualification, but an award. It does not count towards NCEA Level 3 or University Entrance.

[Return to Contents](#)

NCEA Results

NZQA results are available in January. These include:

- standards the student entered
- credit value of each standard
- whether the standard was internally or externally assessed
- grade achieved
- number of credits gained in each standard

Results are published on the NZQA website for students to view through each student's login. Posted copies of results are available if students request these online prior to the commencement of the external exams.

Record of Achievement

In addition to receiving a Results Notice for each subject and any certificates that have been completed, NZQA also provides students with a Record of Learning. Year 12 and Year 13 students may apply for this through their learner login, which is found on the NZQA website. Simply create an account by entering the student's NSN number. Year 13 students will automatically be issued with a Record of Learning along with their qualification certificate.

Certificate Endorsement

Students are able to achieve NCEA qualifications with Merit or Excellence endorsements.

- Endorsement with Merit requires 50 credits at Merit or Excellence at the same level or higher.
- Endorsement with Excellence requires 50 credits at Excellence at the same level or higher.

Credits gained over more than one year can be used for endorsement.

Course Endorsement

Students are able to achieve Merit or Excellence endorsements in each course.

- Course endorsement with **Merit** requires 14 credits at Merit or Excellence at the same level or higher. Three or more Merit credits must be gained in internally assessed standards and three or more credits must be gained in externally assessed standards.
- Course endorsement with **Excellence** requires 14 credits at Excellence at the same level or higher. Three or more Excellence credits must be gained in internally assessed standards and three or more credits must be gained in externally assessed standards.

[Return to Contents](#)

How to select options for next year using KAMAR

Option selection is done via the parent portal on the school's KAMAR student management system. Follow the steps below:

1. Login to kamar.kingsway.school.nz
2. The username is the same username that your child uses to access school computers. This is usually "firstname.surname".
3. This site uses the "Residence A Caregiver" password. This has been sent to you several times this year. However, if you still require this please email notices@kingsway.school.nz to request your password.
4. Once into the KAMAR portal you will see a menu bar across the top of the screen. Choose "Course Selection" from this.
5. Once in the course selection screen, choose one course from each column. Select courses from left to right, and in order of preference from most preferred to least preferred. If you require more information about a course, please refer to the relevant section of this Senior Pathways booklet.
6. Lastly, select an "alternate" course as a back-up in case two other courses clash.
7. Exceptions by application (refer to page 12) will be considered after the options selection process has been completed. Select courses on the KAMAR portal with the assumption that there will be no exceptions. If an exception by application is granted, it will be substituted for the courses that have been selected online. If you are granted 6 subjects, then the "alternate" course will be added to your timetable.
8. **Remember to click "save" at the bottom of the screen when you have completed your selection.** You can re-enter this screen and change the subjects selected if needed. Remember to click "save" again when finished. Courses can be altered up until close off day on Monday, 12 August.

[Return to Contents](#)

Subject Selection - Timeline

Thursday, 1 August 2024	Options Evening Subject Selection goes 'live' Year 10-12 students (2024) start praying, planning and making subject selection
Monday, 12 August 2024	Option Selection complete . All subject selections must be complete by this time. Parent portal will be closed so that the 2025 timetable can be created. December – selection confirmed
December 2024	Option lines produced Accepting / Pending and Declining Phase <u>Current Year 10 students</u> <ul style="list-style-type: none"> - Subject selection confirmed - Clashes notified <u>Current Year 11 – 12 students</u> <ul style="list-style-type: none"> - Subject selection status confirmed as PENDING and “SUBJECT TO CONFIRMATION” OF NCEA RESULTS IN JANUARY - Clashes notified
January 2025	Results of NZQA qualifications published <u>Current Year 11 – 12 students</u> <ul style="list-style-type: none"> - Subject selection checked against NCEA RESULTS - Students who have not met pre-requisite requirements will be asked to meet with staff to discuss subject selection before the start of the 2025 academic year

University Entrance

All universities have a common minimum requirement that students must attain to gain entry to a Bachelor's Degree and this is comprised of the following:

NCEA Level 3, Plus a minimum of:

- Literacy (5 specified reading credits and 5 specified writing credits from Level 2 and/or Level 3)
- Three university approved subjects at Level 3 with at least 14 credits in each
[Here is the link to NZQA approved subjects/standards](#)

Individual universities may impose additional requirements to this standard for entry to a specific course, so it is important that you research the entry criteria for all possible providers carefully.

[Return to Contents](#)

University Approved Subjects offered by KingsWay School

These courses are approved by universities because they contain 14 credits or more that are all from the same domain on the NZQA framework.

Accounting	Earth and Space Science	Spanish
Business Studies	Economics	Statistics
Biology	English	Visual Art – Design
Calculus	Geography	Visual Art – Painting
Chemistry	Hard Materials Technology	Visual Art – Printmaking
Dance	History	
Design and Visual Communications	Media Studies	
Technology	Music	
Digital Technology	Physical Education	
Drama	Physics	

Kingsway offers the following courses that contain Level 3 credits, so they contribute toward Level 3 NCEA, but they cannot be counted as one of the three University approved subjects:

- Tourism
- Hospitality
- Adventure Based Leadership
- Gateway

University approved subjects can be found in this [link](#).

Exceptions By Application

KingsWay Senior School Staff want students to be able to pursue the academic pathway that best fits their learning needs and future career aspirations. In addition to the options outlined in this booklet, students may apply for the exceptions outlined below:

SIXTH SUBJECT APPLICATION – Selection will be based on exceptional academic performance in the previous year with a GPA of at least 80% and proven study and time management skills. Students who take 6 subjects will not be able to complete a course in Biblical Studies. They will also not have any study classes in which to catch up or do homework. [6th Subject Application form](#)

APPLICATION TO ACCELERATE - In some cases, students may wish to select a subject in a year ahead of their current level. These applications will be considered on a case-by-case basis where students have proven study skills and exceptional ability in a subject area. [Acceleration Application form](#)

CORRESPONDENCE SCHOOL SUBJECTS (COR) IN SENIOR SCHOOL (Years 11-13)

- Limited to 1x COR subject per student
- Where there are subject clashes for Year 12 and 13 students – if available via COR and no other option
- Option for Gifted and Talented students
- Situations where the subject is not offered at KingsWay (but accessing it via COR will help the student achieve future aspirations)
- Potential COR students must have a prior history of being hard-working, independent learners
- Parents need to commit to assisting the student at home to understand requirements and get assignments posted away in time

[Application for Correspondence School Subject](#)

Access to the Exceptions above is at the discretion of the Head of Senior School (HOSS) and are only available through the above link.

YEAR 11 SCIENCE – This subject is not compulsory at Year 11 but it is strongly recommended as it leads to many options later at school, and is also a necessity for many careers. Students will not be able to do Chemistry or Physics at Year 12 or 13 without first completing the Year 11 Science Course (11SCI). If the “No Science” option is selected on KAMAR, a Science HOF will contact the family to discuss the implications of this decision before approving that the student be given their “1st Backup Option” in place of Year 11 Science.

LEVEL 2 ENGLISH - This subject is not compulsory at Year 12, but it is strongly recommended because it is the most straightforward way for a student to gain the literacy credits that are required for University Entrance. *If the “Exemption from English” option is selected on KAMAR, a pastoral staff member will contact the family to discuss the implications of this decision before approving that the student be given their “1st Backup Option” in place of Level 2 English.

*If a student does not have 10 credits in Level 2 English and they want to go to the University of Auckland they will need to complete a specific literacy paper in their first year.

[Return to Contents](#)

Costs

Estimated cost per student to provide each course

This year we have indicated to parents the cost to run each course. This is based on costs from previous years and covers materials, field trips that are linked to assessment, and other consumable resources. It does not include stationery. Course costs will be finalised and included on the OfficeMax website in December.

NCEA Fees

NCEA is free for New Zealand students. International students are required to pay NCEA fees. If you have any questions please contact the Principal's Nominee principalsnominee@kingsway.school.nz.

Bring Your Own Devices (BYOD)

Devices are compulsory for all Year 11-13 students in 2025. Please refer to the KingsWay School website for the specifications. The link is:

<https://kingsway.school.nz/our-schools/digital-innovation/>

[Return to Contents](#)

Pathways Planner

Use this form to organise your investigation into possible careers and study options. Biblical Studies and Core Physical Education (Year 11) are woven into the timetables.

* See www.careers.govt.nz for more information

Course Pathways (*= Compulsory)			
Faculty	Year 11	NCEA Level 2	NCEA Level 3
Arts	Dance	Dance	Dance
	Drama	Drama	Drama
	Music	Music	Music
	Visual Art	Visual Art - Paint	Visual Art - Paint
			Visual Art - Printmaking
			Visual Art - Design
Business	Accounting	Accounting	Accounting
	Business Economics	Business Economics	Economics
			Business Studies / Young Enterprise
English and Languages	English* (ENG) or	English (ENG) or	English
	English Essentials * (ENE)	English Essentials (ENE)	
	English to Speakers of Other Languages (ESOL)	English to Speakers of Other Languages (ESOL)	English to Speakers of Other Languages (ESOL)
	Second Language English (SLE)	Second Language English (SLE)	
		Media Studies	Media Studies
	Spanish	Spanish	Spanish
Mathematics	Mathematics * (MAT) or	Calculus	Calculus
	Mathematics Essentials* (MAE)		
		Statistics	Statistics
Physical Education		Outdoor Education	Adventure Based Leadership
	Physical Education* (PEC*, PES)	Physical Education	Physical Education
Science	Science (SCI) or		Earth and Space Science
	Science Essentials (SCE)		
		Biology	Biology
		Chemistry	Chemistry
	Physics	Physics	

Course Pathways (*= Compulsory)

Faculty	YEAR 11	NCEA Level 2	NCEA Level 3
Social Science	Geography	Geography	Geography
	History	History	History
		Travel and Tourism	Travel and Tourism
Biblical Studies	Biblical Studies * or	Biblical Studies * or	Biblical Studies *
	Religious Studies	Religious Studies	
Technology	Design and Visual Communications	Design and Visual Communications	Design and Visual Communications
	Digital Technology	Digital Technology	Digital Technology
	Hard Materials Technology	Hard Materials Technology	Hard Materials Technology
	Hospitality	Hospitality	Hospitality
Gateway		Gateway	Gateway
ILP	Independent Learning Programme (ILP)	Independent Learning Programme (ILP)	Independent Learning Programme (ILP)

Year 11 Courses - 2025

The Year 11 Qualification includes rigorous academic learning and content and is designed to best prepare students for NCEA Level 2 Subjects. The Qualification will include courses that will safeguard learning and necessary skill development to thoroughly prepare students for NCEA Level 2.

Each course will be assessed using a mix of assessment methods including KingsWay Examinations in Term 4.

The Year 11 Qualification includes:

1. Stimulating and rigorous learning and content that will equip learners with the skill set for success in Level 2 in 2026
2. Opportunities for form assessment and recognition of achievement
3. NCEA literacy and numeracy requirements, through the co-requisites.

The Qualification includes existing opportunities such as:

1. Opportunities to accelerate and support learning based on learner readiness
2. Education outside the classroom excursions within curriculum areas
3. Enriching cultural and special character programmes.

Compulsory subjects in Year 11 are:

1. Biblical Studies (or Religious Studies)
2. English or Second Language English (ESL)
3. Mathematics
4. Core Physical Education (1 period)

Optional Subjects

Select FOUR from list below – in order of preference with the fourth subject being a BACKUP:

- Accounting
- Business Economics
- Dance
- Digital Technology
- Design and Visual Communications Technology
- Drama
- Geography
- Hard Materials Technology
- History
- Hospitality
- Music
- Physical Education Studies
- Science 
- Spanish
- Visual Art

EXCEPTIONS BY APPLICATION

At KingsWay we want to see students in programs that meet their learning needs. See the section on page 11 for permissible exceptions to the criteria above and the application process required for these.

▲ It is strongly recommended that students take Science at this level. If a student opts not to take Science, they will be contacted by a pastoral staff member to ensure that they understand the implications of this decision.

[Return to Contents](#)

Year 11 – Art (ART)

Year 11 Art students will study the work and techniques of several artists from around the world. They will show an influence of these artists while creating their own work. Students will use a variety of media which include pencil, paint and print to generate, develop and clarify their ideas.

Prerequisites: None

EOTC Days	1	Estimated Trip Costs	\$35	Costs	\$40
------------------	----------	-----------------------------	-------------	--------------	-------------

Year 11 - Biblical Studies (BST)

Year 11 Biblical Studies is designed to develop a foundation of Biblical knowledge that equips students to think and evaluate from a Christian perspective. Students are encouraged to “own” their faith and engage with the world in which they live. Topics include:

- Genesis
- Grace & Law
- Major themes of Ephesians
- Church History

Prerequisites: None

EOTC Days	0	Estimated Trip Costs	\$0	Costs	\$0
------------------	----------	-----------------------------	------------	--------------	------------

Year 11 – Accounting (ACC)

Year 11 Accounting provides students with a solid introduction to accounting practice and analysis. Understanding the accounting process and being able to analyse financial information is a very valuable skill and useful to careers in business and management or running a business of your own. As technology enables much of the traditional book-keeping activities to be automated, the demand for those who can understand financial information and provide quality advice will be higher than ever. The course includes how Excel spreadsheets can be used to organise financial data as well as an introduction to the Xero accounting software used by many businesses.

Prerequisites: None

EOTC Days	0	Estimated Trip Costs	\$0	Costs	\$30
------------------	----------	-----------------------------	------------	--------------	-------------

[Return to Contents](#)

Year 11 – Business Economics (BEC)

This course introduces how businesses use the Marketing Mix to increase their sales and profits and the Human Resource decisions that allow them to have the staff required to achieve these goals, including the importance of CV's, interviews and training. There is an introduction to the basic economic principles of how supply and demand combine to determine market prices as well as learning about investment options such as the sharemarket and Kiwisaver.

Prerequisites: None

EOTC Days	1	Estimated Trip Costs	\$25	Costs	\$50
------------------	----------	-----------------------------	-------------	--------------	-------------

Year 11 – Dance (DAN)

Year 11 Dance explores different genres of dance and introduces students to the performance skills within these genres. They will also begin learning the fundamental building blocks of choreography and what aspects of learning take place within a creative process. Arts Week is an annual highlight for all students where they showcase the work they have accomplished throughout the year.

Prerequisites: None

EOTC Days	1	Estimated Trip Costs	\$80	Costs	\$85
------------------	----------	-----------------------------	-------------	--------------	-------------

Year 11 – Drama (DRA)

Year 11 Drama builds from Year 10 and explores the fundamentals of dramatic elements, techniques and conventions with more depth. Students learn how to manipulate these key aspects of drama for the purpose of creating convincing characters, powerful stories whilst also exploring varied styles of theatre. Year 11 Drama introduces the *why* behind aspects of dramatic theatre, laying a foundation for and encourages critical thinking skills. Students also have a chance to view a live performance and will write an external on the aspects of the show.

Prerequisites: None

EOTC Days	1	Estimated Trip Costs	\$85	Costs	\$70
------------------	----------	-----------------------------	-------------	--------------	-------------

[Return to Contents](#)

Year 11 – English (ENG)

Year 11 English focuses on developing the skills of reading, writing, listening, speaking, viewing and presenting through the study of novels, short texts, drama, film and poetry. Research skills are also developed and lay an important foundation for future study, not only in English but in all other disciplines. Learning the art of communicating effectively in both the written and spoken mode is at the heart of Year 11 English.

Prerequisites: None

EOTC Days	0	Estimated Trip Costs	\$0	Costs	\$26
------------------	----------	-----------------------------	------------	--------------	-------------

Year 11 – English Essentials (ENE)

This course covers the skills of reading, writing, listening, speaking, viewing and presenting. Research skills and the study of literary and non-literary texts are also important parts of the course. The course is designed to support students who find English challenging and to prepare them for Year 12 ENE which offers no External Assessments, yet still provides opportunity to gain UE Literacy.

Prerequisite: This course is by HOF invitation only

EOTC Days	0	Estimated Trip Costs	\$0	Costs	\$26
------------------	----------	-----------------------------	------------	--------------	-------------

Year 11 - English – Second Language English (SLE)

This English course is aimed at students for whom English is a second language. Being eligible for this course is subject to both HOF approval and placement testing for non-domestic students. There will be a large focus on pronunciation, grammar and vocabulary. This course is a pathway for L2 SLE and the ultimate goal is to provide students with opportunities to gain the literacy credits necessary for University Entrance Literacy. As this course offers an individualised pathway, more standards may be offered towards the end of the year dependent on the capability of the student and in negotiation with the school.

Prerequisites: Subject to HOF approval.

EOTC Days	0	Estimated Trip Costs	\$0	Costs	\$26
------------------	----------	-----------------------------	------------	--------------	-------------

[Return to Contents](#)

Year 11 – Geography (GEO)

Year 11 Geography focuses on the relationship between people and the environments that they live in. Our topics include Weather, Tropical Cyclones, Volcanos and Sustainability in the Maldives. We will be doing a practical weather research investigation as part of the course.

Prerequisites: None

EOTC Days	0	Estimated Trip Costs	\$0	Costs	\$0
------------------	----------	-----------------------------	------------	--------------	------------

Year 11 - History (HIS)

Year 11 History uses selected case studies to look at two major historical forces of the 20th century that have shaped our modern world; injustice and social action / protest. It considers the issues that drive people to conflict, as well as the factors that allow peaceful resolution leading to more stable societies.

Prerequisites: None

EOTC Days	0	Estimated Trip Costs	\$0	Costs	\$0
------------------	----------	-----------------------------	------------	--------------	------------

Year 11 - Mathematics (MAT)

All Year 11 students will choose either Mathematics (MAT) or Mathematics Essentials (MAE).

This Year 11 Mathematics course aims to provide students with a solid foundation in mathematical concepts and skills. It covers a wide range of topics that are essential for further study in all areas of mathematics but has a key focus on Algebra. The course emphasizes problem-solving, critical thinking, and practical applications of mathematical principles. All the strands of algebra, number, geometry, trigonometry, statistics, probability, graphs, and functions are covered in this course. Students who take this course may choose to study Level 2 Calculus or Statistics.

Prerequisites: None

EOTC Days	0	Estimated Trip Costs	\$0	Costs	\$60
------------------	----------	-----------------------------	------------	--------------	-------------

[Return to Contents](#)

Year 11 - Mathematics Essentials (MAE)

This Year 11 Mathematics course aims to provide students with a solid foundation in mathematical concepts and skills. It covers a wide range of topics that are essential for further study in Mathematics but has a key focus on Statistics and Numeracy. The course emphasizes problem-solving, critical thinking, and practical applications of mathematical principles. The strands of number, geometry, trigonometry, statistics, and probability are all covered in this course. Students who take this course may choose to study Level 2 Statistics only.

Prerequisites: None

EOTC Days	0	Estimated Trip Costs	\$0	Costs	\$60
------------------	----------	-----------------------------	------------	--------------	-------------

Year 11 - Music (MUS)

Year 11 Music aims to build on the skills and techniques learned during the Year 10 Music Course. Students will be given opportunities to deepen their understanding and further develop their abilities in the areas of Composition, Performance, Aural Skills and Theory Concepts. Furthermore, students will have the opportunity to choose their own learning programme from a variety of unit standards and achievement standard assessments.

Prerequisites: Year 10 Music or HOF approval. Instrumental and / or vocal ability experience required.

EOTC Days	1	Estimated Trip Costs	\$50	Costs	\$90
------------------	----------	-----------------------------	-------------	--------------	-------------

Year 11 - Physical Education Studies (PES)

Students will actively participate in a wide range of physical activities and sports. They will develop skills, tactics and knowledge to enhance sports performance. Students will apply learning in a variety of settings including some outdoors adventure activities. Participation in this course includes approximately 50% theory work and 50% practical work throughout the year. Trips and activities for this course will involve mountain biking and tree adventures where students apply concepts covered in class in an applied setting.

Prerequisites: None

EOTC Days	2	Estimated Trip Costs	\$100	Costs	\$0
------------------	----------	-----------------------------	--------------	--------------	------------

[Return to Contents](#)

Year 11 - Religious Studies (RST)

The Year 11 Religious Studies course includes the History of Christianity from its foundations to the modern era, with particular emphasis on the Reformation. Students choose either Religious Studies (RST) or Biblical Studies (BST). Students who select Year 11 RST have one less PE class per week.

Prerequisites: None

EOTC Days	0	Estimated Trip Costs	\$0	Costs	\$16
------------------	----------	-----------------------------	------------	--------------	-------------

Year 11 - Science (SCI)

At Year 11 students will be placed into either Science – SCI or Science Essentials –SCE.

Year 11 Science – SCI is a comprehensive and practical course that builds extensively on the Year 10 foundation, allowing students to continue through to all pathways in Science. It applies the knowledge gained in Year 10 and prepares students for all NCEA subjects. During the course, the students develop an understanding of the fundamental concepts of Science. They will apply these principles to familiar and unfamiliar situations, perform experiments, collect and interpret data and draw logical conclusions. Study skills, independent learning and organised revision habits will be encouraged throughout the course.

This course prepares students for all of NCEA Level 2 Biology, Chemistry and Physics.

Prerequisites: None

EOTC Days	1	Estimated Trip Costs	\$50	Costs	\$27
------------------	----------	-----------------------------	-------------	--------------	-------------

[Return to Contents](#)

Year 11 - Science Essentials (SCE)

At Year 11, students will be placed into either Science – 11SCI or Science Essentials – 11SCE, based on Year 10 results and teacher/parent recommendations.

Year 11 Science Essentials –SCE is designed to cater for the students who have struggled with Year 10 Science or who have already decided that they will not be pursuing Physics or Chemistry at Level 2 NCEA. The main objectives for this course are enjoyment and learning of Science at an appropriate pace to achieve success while developing the skills to understand and discuss important science concepts. The course is designed to facilitate a supportive environment where students can pursue deeper understanding of content related to the topics they are most interested in, while being equipped to contribute positively to society at large.

Please Note: Progress into level 2 Science options (Biology, Chemistry, Physics) is dependent on results from Year 11 Science (SCI and SCE), however, students from Year 11 SCE *must choose to complete additional relevant assessment tasks during the year for entry to Level 2 NCEA Science.*

Prerequisites: None

EOTC Days	1	Estimated Trip Costs	\$50	Costs	\$27
-----------	---	----------------------	------	-------	------

Year 11 – Spanish (SPA)

Year 11 Spanish focuses on a communicative, task based, intercultural approach incorporating online tools to develop the student’s ability to interact and deepen their understanding of Spanish language and cultures. Topics covered include daily life, leisure, future ambitions, travel and well-being, all from a biblical perspective. Students will have the opportunity to experience Spanish/Latin American food and attend film festivals.

Prerequisites: Year 10 grades or higher achieved in Spanish, or assessment by Spanish Teacher in special circumstances

EOTC Days	0.5	Estimated Trip Costs	\$20	Costs	\$55
-----------	-----	----------------------	------	-------	------

[Return to Contents](#)

Year 11 - Technology – Design and Visual Communication (DVC)

The Year 11 DVC programme follows the NZQA design and visual communication technology Achievement Standard course. This is intended to provide secondary students with graphics and technology skills which involves design and mastering of Computer Aided applications such as Fusion 360.

The system requirements for DVC are as follows:

- Operating System: macOS [Ventura, Monterey, or Big Sur] or Windows 11/Windows 10 (Version 1809 or newer).
- Processor: 64-bit CPU (Intel or AMD); 4 cores or greater; 1.7 Ghz or greater / Intel-based Mac devices or Apple Silicon ones (Fusion 360 still has to be emulated through Rosetta 2)
- Memory: 4 GB of RAM (integrated graphics recommended)
- Graphics Card: DirectX11 (Direct3D 10.1 or greater) Dedicated GPU with 1 GB or more of VRAM (integrated graphics not recommended)
- Disk Space: 8.5 GB of storage

Prerequisites: None

EOTC Days	0	Estimated Trip Costs	\$0	Costs	\$65
------------------	----------	-----------------------------	------------	--------------	-------------

Year 11 - Technology – Digital Technology (DGT)

This course builds on two new curriculum areas: Computational thinking for digital technologies, where students will develop an understanding of computer science principles that underlie all digital technologies, and Designing and developing digital outcomes, where students learn how to design digital robotic solutions that are fit-for-purpose. This course has been designed to give students exposure to a wide range of learning areas. Standards undertaken cover digital information (databasing), digital media (video/web development), robotics and electronics outcomes, as well as programming (game development).

The system requirements for DGT are as follows:

- Operating System: macOS [Ventura, Monterey, or Big Sur] or Windows 11/Windows 10 (Version 1809 or newer).
- Processor: 64-bit CPU (Intel or AMD); 4 cores or greater; 1.7 Ghz or greater / Intel-based Mac devices or Apple Silicon ones (Fusion 360 still has to be emulated through Rosetta 2)
- Memory: 4 GB of RAM (integrated graphics recommended)
- Graphics Card: DirectX11 (Direct3D 10.1 or greater) Dedicated GPU with 1 GB or more of VRAM (integrated graphics not recommended)
- Disk Space: 8.5 GB of storage

Prerequisites: None

EOTC Days	0	Estimated Trip Costs	\$0	Costs	\$25
------------------	----------	-----------------------------	------------	--------------	-------------

[Return to Contents](#)

Year 11 - Technology – Hard Materials Technology (HMT)

The Year 11 Hard Materials Technology programme follows the NCEA Curriculum. This is intended to provide secondary students with a well-balanced, practically orientated mechanical engineering course that develops lifelong skills, stimulates self-esteem and confidence, and generates a sense of pride in paying attention to detail.

Prerequisites: None

EOTC Days	0	Estimated Trip Costs	\$0	Costs	\$125
------------------	----------	-----------------------------	------------	--------------	--------------

Year 11 - Technology – Hospitality (HOS)

Year 11 Hospitality will be focusing on career opportunities in the Hospitality Industry. We will maximise our time in the commercial kitchen through practical application and some supporting theoretical concepts of the Hospitality Industry, such as:

Preparing and presenting fruit, vegetable, egg and cheese dishes, sauces, soups and meat dishes. Baking cakes, sponges and scones as in the hospitality industry.

Students will gain Unit Standard credits after demonstrating their competency. Knowledge will be assessed through written and oral modes, as well as demonstrations in a practical environment.

Prerequisites: None

EOTC Days	0	Estimated Trip Costs	\$0	Costs	\$225
------------------	----------	-----------------------------	------------	--------------	--------------

[Return to Contents](#)

Level 2 Courses - 2025

National Certificate of Educational Achievement – Level 2

60 credits of achievement or unit standards must be gained. These may be 60 Level 2 credits or a minimum of 60 Level 2 credits.

The compulsory subject: Biblical Studies or Religious Studies

Optional Subjects

Select **SIX** from the list below – in order of preference with the sixth subject being a **BACKUP**:

Accounting	History
Biology	Hospitality
Business Economics	Media Studies
Calculus	Music
Chemistry	Outdoor Education
Dance	Physics
Digital Technology	Physical Education Studies
Design and Visual Communications Technology	Spanish
Drama	Statistics
English Δ or Second Language English (SLE)	Travel and Tourism
Gateway	Visual Art – Painting
Geography	Visual Art – Printmaking
Hard Materials Technology	

PREREQUISITES - For entry requirements into Level 2 subjects refer to prerequisites and information of the individual subjects.

EXCEPTIONS BY APPLICATION

At KingsWay we want to see students in programmes that meet their learning needs. See the section on page 11 for permissible exceptions to the criteria above and the application process required for these.

Δ Taking English is the most straightforward way to ensure that a student achieves University Entrance level reading and writing credits. If reading and writing is not achieved from English in Level 2 then it can also be achieved from a variety of subjects at Level 2 and Level 3. These include, but are not limited to: Drama, Geography, Media Studies, History, Earth and Space Science (L3) and Business Studies (L3). Please contact relevant Deans or Head of Pathways, Cherie Perrow, to confirm.

[Return to Contents](#)

L2 – Art (ART)

Level 2 Art students will study the work and techniques of printers and painters from Aotearoa. They will show an influence of these artists while creating their own work. Students will use a variety of print and paint techniques to generate, develop and clarify their ideas.

This subject does not carry any literacy or numeracy credits for University Entrance Literacy

Prerequisites: Year 11 Art or HOF approval

Internal Credits	8	External Credits	12	Total	20
-------------------------	----------	-------------------------	-----------	--------------	-----------

EOTC Days	1	Estimated Trip Costs	\$35	Costs	\$40
------------------	----------	-----------------------------	-------------	--------------	-------------

Year 12 - Biblical Studies (BST)

Year 12/13 Biblical Studies is designed to develop a foundation of Biblical knowledge that equips students to think and evaluate from a Christian perspective. Students are encouraged to “own” their faith and be ready to celebrate, critique and confront the world in which they live.

Topics include:

- Worldview and Postmodernism
- Apologetics
- Marriage and Relationships
- Spiritual Beings
- The Bible for Grown-ups

This subject does not carry any literacy or numeracy credits for University Entrance Literacy

Prerequisites: None

Internal Credits	0	External Credits	0	Total	0
-------------------------	----------	-------------------------	----------	--------------	----------

EOTC Days	0	Estimated Trip Costs	\$0	Costs	\$0
------------------	----------	-----------------------------	------------	--------------	------------

[Return to Contents](#)

L2 – Accounting (ACC)

This course builds on the accounting principles learned in Year 11. Students will get the opportunity to work with the popular computer based financial software from XERO and develop a greater understanding of how businesses use cost information to determine prices and profitability of their products. Students will also learn how large businesses have processes to deal with the cost issues arising from carrying stock, as well as developing their skills in interpreting information and giving advice.

Although a study of the Year 11 course is preferred, it is not essential and students with high levels of motivation will be able to join the Level 2 course.

This subject does not carry any literacy or numeracy credits for University Entrance Literacy

Prerequisites: None

Internal Credits	10	External Credits	9	Total	19
-------------------------	-----------	-------------------------	----------	--------------	-----------

EOTC Days	0	Estimated Trip Costs	\$0	Costs	\$50
------------------	----------	-----------------------------	------------	--------------	-------------

L2 – Business Economics (ECO)

This course combines standards from the Business and Economics subjects. It begins with a unit on Motivation – exploring the main theories about why employees want to work hard for an organisation. There is also a practical investigation about how Market Research can help an organisation achieve its goals. Personal financial literacy is covered with units on Insurance and Investment options. It then switches to Economics and explores the key economic issues of inflation and international trade. Why are they issues? How are key factors measured? What role does government play in each? How fair are the outcomes?

An optional trip to Wellington to visit significant public and private sector businesses will run on a two-year cycle (for Level 2 and 3 Business Economics students). This will take place in the October holidays.

This subject carries four reading credits for University Entrance Literacy

Prerequisites: None

Internal Credits	13	External Credits	8	Total	21
-------------------------	-----------	-------------------------	----------	--------------	-----------

EOTC Days	1	Estimated Trip Costs	\$30	Costs	\$50
------------------	----------	-----------------------------	-------------	--------------	-------------

[Return to Contents](#)

L2 – Dance (DAN)

Level 2 Dance builds on the creativity and learning from Year 11. In this class we delve deeper into the ins and outs of a contemporary repertoire with an exploration into different styles and moods within a genre. The choreographic skills are deepened and stretched as the task to create from a place of meaning is worked and collaborated on. This year also combines an adventure into dance from other cultures as we learn a piece from a culture around the world.

Prerequisites: 12 to 14 credits in Year 11 Dance preferred or HOF approval

Internal Credits	18	External Credits	4	Total	22
-------------------------	-----------	-------------------------	----------	--------------	-----------

EOTC Days	1	Estimated Trip Costs	\$80	Costs	\$95
------------------	----------	-----------------------------	-------------	--------------	-------------

L2 – Drama (DRA)

Level 2 Drama expands and deepens the knowledge from Year 11 Drama and allows students to take more initiative with their own learning. Studies of more complex theatre forms and play-texts give students the chance to view the same aspects with different lenses, deepening and strengthening their worldviews and cultural understandings. The focus shifts from proficiency with dramatic tools to understanding and portraying deeper themes and ideas through performance.

This subject offers up to 12 literacy credits.

Prerequisites: Year 11 Drama or HOF approval

Internal Credits	13	External Credits	4	Total	17
-------------------------	-----------	-------------------------	----------	--------------	-----------

EOTC Days	1	Estimated Trip Costs	\$95	Costs	\$70
------------------	----------	-----------------------------	-------------	--------------	-------------

[Return to Contents](#)

L2 – English (ENG)

Level 2 English continues to focus on developing the skills of reading, writing, listening, speaking, viewing and presenting, but with greater competency, in preparation for tertiary study. Novel and film studies are used for external assessment; these also become catalysts for internal assessment. Research skills and the study of literary and non-literary texts are foundational, not only for English but study and success in all other disciplines.

This subject carries eight reading credits and fourteen writing credits for University Entrance Literacy.

Prerequisites: None

Internal Credits	13	External Credits	8	Total	21
-------------------------	-----------	-------------------------	----------	--------------	-----------

EOTC Days	0	Estimated Trip Costs	\$0	Costs	\$26
------------------	----------	-----------------------------	------------	--------------	-------------

L2 - English Essentials (ENE)

Level 2 English Essentials focuses on developing the skills of reading, writing, listening, speaking, viewing and presenting with greater competency, in preparation for tertiary study. Research, film analysis and clear crafted writing are central elements of the course. Being eligible for this course is subject to HOF approval.

This subject carries eight reading credits and six writing credits for University Entrance Literacy.

Prerequisites: Subject to HOF approval.

Internal Credits	19	External Credits	0	Total	19
-------------------------	-----------	-------------------------	----------	--------------	-----------

EOTC Days	0	Estimated Trip Costs	\$0	Costs	\$26
------------------	----------	-----------------------------	------------	--------------	-------------

[Return to Contents](#)

L2 - English – Second Language English (SLE)

This English course is aimed at students for whom English is a second language. In addition to offering Achievement Standards, there will be a large focus on pronunciation, grammar and vocabulary. The ultimate goal of this course is to provide students with opportunities to gain the literacy credits necessary for University Entrance Literacy through English. For some students, this course will take place over two years, depending on individual abilities.

This subject carries eight reading credits and six writing credits for University Entrance Literacy.

Prerequisites: Subject to HOF approval.

Internal Credits	17	External Credits	0	Total	17
-------------------------	-----------	-------------------------	----------	--------------	-----------

EOTC Days	0	Estimated Trip Costs	\$0	Costs	\$26
------------------	----------	-----------------------------	------------	--------------	-------------

L2 – Geography (GEO)

Level 2 Geography continues to explore the relationships between people and both natural and cultural environments. Geographic skills are applied to different environments both at a local and global scale. This course includes a 3-day field trip to Tongariro National Park where students conduct geographic research contributing to their first internal assessment. The trip also allows students to explore the environment which is the context for their external exam.

This subject carries four reading credits.

Prerequisites: Open entry

Internal Credits	14	External Credits	4	Total	18
-------------------------	-----------	-------------------------	----------	--------------	-----------

EOTC Days	3	Estimated Trip Costs	\$320	Costs	\$0
------------------	----------	-----------------------------	--------------	--------------	------------

[Return to Contents](#)

L2 – History (HIS)

Level 2 History focuses on a range of contemporary global issues and decisions of significance to New Zealanders which have shaped our modern world. The rise of Islamic Militarism and the connection with the 911 Terror Attacks are covered in detail. Causes of the Israel / Palestine conflict and its consequences are also analysed.

This subject carries either nineteen reading credits or nine writing credits for University Entrance Literacy.

Prerequisites: None

Internal Credits	10	External Credits	9	Total	19
-------------------------	-----------	-------------------------	----------	--------------	-----------

EOTC Days	0	Estimated Trip Costs	\$0	Costs	\$0
------------------	----------	-----------------------------	------------	--------------	------------

L2 - Mathematics – Calculus (MAC)

Level 2 Calculus introduces students to the basic concepts and techniques of calculus with a focus on developing students' understanding of differentiation and its applications. The course also covers a large range of skills in algebra, graphical models, trigonometry, co-ordinate geometry and systems of equations. There are two externally assessed standards. Students who take this course may choose to study Level 3 Calculus or Statistics.

This subject does not offer any credits for University Entrance Literacy.

Prerequisites: 12 achieved credits at Year 11 Mathematics. Students who have not met these prerequisites can apply to the HOF for discretionary entry into this course.

Internal Credits	11	External Credits	9	Total	20
-------------------------	-----------	-------------------------	----------	--------------	-----------

EOTC Days	0	Estimated Trip Costs	\$0	Costs	\$53
------------------	----------	-----------------------------	------------	--------------	-------------

[Return to Contents](#)

L2 - Mathematics – Statistics (MAS)

Level 2 Statistics introduces students to fundamental concepts and techniques in statistics. The course teaches data collection methods, organization, and experimental design. Statistical methods are used to make inferences and networks are used to solve problems. Probability methods are used to solve problems and elements of chance are investigated through simulation. Students will learn to apply statistical methods to real-world scenarios to make informed decisions based on data. There is one externally assessed standard. Students who take this course may choose to study Level 3 Statistics.

This subject does not offer any credits for University Entrance Literacy.

Prerequisites: 8 Achieved credits at Year 11 Mathematics or Mathematics Essentials. Students who have not met these prerequisites can apply to the HOF for discretionary entry into this course.

Internal Credits	14	External Credits	4	Total	18
-------------------------	-----------	-------------------------	----------	--------------	-----------

EOTC Days	0	Estimated Trip Costs	\$0	Costs	\$8
------------------	----------	-----------------------------	------------	--------------	------------

L2 – Media Studies (MST)

Level 2 Media Studies focuses on examining media in society and helping students understand their own relationship with the media to make them 'critical, active, informed and responsible citizens' (NZC). In a three-pronged approach, students learn about media in society, exploring different media texts (e.g. film, print and digital media); secondly, they interpret layers of meaning in a variety of contexts by reading media texts, and considering their own and others' media use. Thirdly, through media production, they apply this knowledge of media conventions and technology to create their own short film by working collaboratively in small groups.

This subject carries seven writing credits for University Entrance Literacy. It offers sixteen internal credits and four external credits.

Prerequisites: None

Internal Credits	16	External Credits	4	Total	20
-------------------------	-----------	-------------------------	----------	--------------	-----------

EOTC Days	2	Estimated Trip Costs	\$150	Costs	\$50
------------------	----------	-----------------------------	--------------	--------------	-------------

[Return to Contents](#)

L2 – Music (MUS)

Level 2 Music aims to build on the skills and techniques learned during the Year 11 Music Course. Students will be given opportunities to deepen their understanding and further develop their abilities in the chosen areas of Composition, Song Writing, Performance, Instrumentation, Aural Skills or Theory Concepts. Students will be able to choose their own learning programme to support their own musical learning goals. Music theory is not required for this course.

This subject does not offer any credits for University Entrance Literacy.

Prerequisites: 12 to 14 credits in Year 11 Music preferred or HOF approval. Instrumental and / or vocal ability or experience is required.

Internal Credits	16-27	External Credits	4-8	Total	22
-------------------------	--------------	-------------------------	------------	--------------	-----------

EOTC Days	0	Estimated Trip Costs	\$50	Costs	\$90
------------------	----------	-----------------------------	-------------	--------------	-------------

[Return to Contents](#)

L2 – Pathways – Gateway (GAT)

The Gateway programme is designed to equip Year 12 students with transferable skills and industry exposure, preparing them to be work-ready. Gateway provides valuable insights into students' skills, strengths, values, and personality, helping them explore preferred pathways beyond school.

Programme Highlights

- **Personalised Learning:** Students develop individualised learning plans tailored to their interests, strengths, and career aspirations.
- **Self Awareness:** Students explore, using Gallup Strength Finders, the strengths and talents that God has given them and how to action them effectively in their lives. This reinforces their identity as his unique and purposeful creation, enriches their sense of belonging and provides insight into what he may be calling them.
- **Programme:** Through workshops and practical applications, students acquire employability and transferable life skills and earn a certificate to enhance their CVs.
- **Industry-Relevant Courses:** Students participate in work-ready courses and short courses relevant to their chosen industries.
- **Structured Workplace Learning:** Students engage in formal workplace arrangements, gaining hands-on experience and employability skills, enabling them to make informed career decisions.
- **Accredited Learning:** Some work placements offer the opportunity to be assessed against unit standards on the New Zealand Qualifications Framework (NZQF) and integrated into the students' learning programme.

Entry Requirements

- Year 12 Students: Open entry to all Year 12 students.
- Interview Process: Students must undergo an interview to assess their suitability and commitment to the programme.
- Work Placement Arrangements: Students and their whānau are expected to help arrange and support, in conjunction with the Gateway Co-ordinator, the requirements to fulfill the work placement.

Qualifications Earned

- Earn a minimum of 15 NCEA level 2 credits.

Cost

- Free of charge, funded through the Tertiary Education Commission.

[Return to Contents](#)

L2 - Physical Education – Outdoor Education (OED)

The Level 2 Outdoor Education course at KingsWay School is a comprehensive programme designed to build foundations for a future of enjoying, recreating and connecting with God in the great outdoors. The course aims to enhance opportunities for examining, theorising, experiencing, and applying processes of learning in the outdoors through adventure, challenge, environmental sustainability and leadership opportunities.

Each term focuses on a specific outdoor discipline. Alongside these disciplines are unit and achievement standards that contribute to 19 NCEA credits. The delivery of these units is both a mix of theory and practical sessions. Double periods are often used for off-campus practical sessions; and single periods for classroom-based theory. It is important to note that to achieve in these unit standards students need to meet the performance criteria for BOTH written and practical components.

This course is significantly STAR funded by the school, which aids in the costs of activities and camps. Overnight camps will be based around Rock Climbing, Surfing and Tramping.

This subject does not offer any credits for University Entrance Literacy.

Prerequisites: None

Internal Credits	19	External Credits	0	Total	19
-------------------------	-----------	-------------------------	----------	--------------	-----------

EOTC Days	10	Estimated Trip Costs	\$699	Costs	\$0
------------------	-----------	-----------------------------	--------------	--------------	------------

L2 – Physical Education Studies (PES)

Students will build on knowledge acquired in Year 11 Physical Education and use this to analyse and develop performance in physical activities and sports. Students will look to develop both leadership skills and apply these to developing movement skills relating to non-traditional sports. This course includes approximately 50% theory work and 50% practical work throughout the year. The course would be suitable for anyone with a general interest in sports and improving performance. Practical activities include badminton, adventure running and turbo touch (depending on class numbers and logistics).

This subject does not offer any credits for University Entrance Literacy.

Prerequisites: Approval required from HOF if Year 11 PES has not been completed.

Internal Credits	21	External Credits	0	Total	21
-------------------------	-----------	-------------------------	----------	--------------	-----------

EOTC Days	1	Estimated Trip Costs	\$50	Costs	\$120
------------------	----------	-----------------------------	-------------	--------------	--------------

[Return to Contents](#)

Year 12 - Religious Studies (RST)

The Year 12 Religious Studies course offers two NCEA Achievement Standards worth 12 credits. Topics include Christianity and World Religions and a practical portfolio-based unit on Servant Leadership. Students choose either Religious Studies (RST) or Biblical Studies (BST). Students who select Year 12 RST have one less study class per week.

Prerequisites: None

EOTC Days	0	Estimated Trip Costs	\$0	Costs	\$0
------------------	----------	-----------------------------	------------	--------------	------------

L2 – Science – Biology (BIO)

Level 2 Biology is a course that comprises of three modules of study:

- Comparative animal Biology – an exploration into the animal kingdom to understand how they are adapted to live in their habitats.
- Cell Biology - A study of the structure and processes of plant and animal cells.
- Genetic Change and Gene Expression - A detailed look at the fascinating world of Genetics.

Course fees are for Education Perfect online resource (students pay only once if taking Chemistry, Biology or Physics at Level 2).

This subject carries eight writing credits and four numeracy credits for University Entrance Literacy

Prerequisites: None.

Internal Credits	7	External Credits	12	Total	19
-------------------------	----------	-------------------------	-----------	--------------	-----------

EOTC Days	1	Estimated Trip Costs	\$60	Costs	\$30
------------------	----------	-----------------------------	-------------	--------------	-------------

[Return to Contents](#)

L2 - Science – Chemistry (CHE)

Level 2 Chemistry is the study of the composition and properties of matter, and its reactions. Level 2 Chemistry is very practical with an emphasis on Chemistry in the 21st Century. The topics covered will include Oxidation-Reduction reactions, Bonding, Structure and Energy Changes, Organic Chemistry, Chemical Reactivity and Quantitative Analysis. Course fees are for the Education Perfect online resource (students pay only once if taking Chemistry, Biology or Physics at Level 2).

This subject does not offer any credits for University Entrance Literacy.

Prerequisites: Total 12 credits from KingsWay Year 11 Qualification : 4 credits from the Acids and Bases plus 8 other credits from Year 11 Science, HOF discretion.

Internal Credits	7	External Credits	13	Total	20
-------------------------	----------	-------------------------	-----------	--------------	-----------

EOTC Days	0	Estimated Trip Costs	\$0	Costs	\$30
------------------	----------	-----------------------------	------------	--------------	-------------

L2 – Science – Physics (PHY)

Level 2 Physics introduces students to the fundamental laws that govern the classical physical universe. The topics covered will include: Mechanics (motion, forces and energy), Optics and Waves, Radioactivity and Nuclear Physics, Electricity and Electro-Magnetism. There will be experimental work set during the year. Course fees are for the Education Perfect online resource (students only pay once if taking Chemistry, Biology or Physics at Level 2).

This subject does not offer any credits for University Entrance Literacy.

Prerequisites: Total 12 credits : 4 credits from the Mechanics plus 8 other credits from Year 11 Science, HOF discretion.

Internal Credits	6	External Credits	14	Total	20
-------------------------	----------	-------------------------	-----------	--------------	-----------

EOTC Days	1	Estimated Trip Costs	\$45	Costs	\$30
------------------	----------	-----------------------------	-------------	--------------	-------------

[Return to Contents](#)

L2 – Spanish (SPA)

Level 2 Spanish focuses on expressing and justifying ideas and opinions in a range of different contexts. Spanish and Latin American culture is explored from a biblical perspective within the following topics: building community, media and technology, wellbeing, travel and missions. Students will have the opportunity to experience Spanish/Latin American food and attend film festivals.

This subject does not offer any credits for University Entrance Literacy.

Prerequisites: 8 credits or more achieved in Year 11 Spanish or an equivalent level of spoken and written Spanish.

Internal Credits	9	External Credits	10	Total	19
-------------------------	----------	-------------------------	-----------	--------------	-----------

EOTC Days	0.5	Estimated Trip Costs	\$20	Costs	\$60
------------------	------------	-----------------------------	-------------	--------------	-------------

L2 - Technology – Design and Visual Communication (DVC)

Level 2 DVC programme follows the NZQA Design and Visual Communication technology achievement standard course. This is intended to provide secondary students with Graphic and Technology skills which involves design and mastering of Computer Aided applications such as Fusion 360.

The system requirements for DVC are as follows:

- Operating System: macOS [Ventura, Monterey, or Big Sur] or Windows 11/Windows 10 (Version 1809 or newer).
- Processor: 64-bit CPU (Intel or AMD); 4 cores or greater; 1.7 Ghz or greater / Intel-based Mac devices or Apple Silicon ones (Fusion 360 still has to be emulated through Rosetta 2)
- Memory: 4 GB of RAM (integrated graphics recommended)
- Graphics Card: DirectX11 (Direct3D 10.1 or greater) Dedicated GPU with 1 GB or more of VRAM (integrated graphics not recommended)
- Disk Space: 8.5 GB of storage

This subject does not offer any credits for University Entrance Literacy.

Prerequisites: 8 credits Year 11 or HOF approval. Graphics pack required, can use from previous years

Internal Credits	12	External Credits	7	Total	19
-------------------------	-----------	-------------------------	----------	--------------	-----------

EOTC Days	0	Estimated Trip Costs	\$50	Costs	\$65
------------------	----------	-----------------------------	-------------	--------------	-------------

[Return to Contents](#)

L2 – Technology – Digital Technology (DGT)

This course covers the revised Digital Technologies Curriculum which are intended to reflect the realities of the ever-changing workplace and the role that Digital Technologies increasingly plays in career paths. One skill that is being developed is the ability to think through implications as outcomes are designed and implemented. This involves ‘thinking through’ what could happen and why before proceeding down a path on a particular course of action. Students will produce a Digital Technology Outcome (Mobile / Web App), and a Digital Media Outcome (Website). These outcomes will be planned and developed using agile project management processes and tools. There is a maximum of 25 credits available at Level 2 Digital Technologies, depending on the standards chosen.

The system requirements for DGT are as follows:

- Operating System: macOS [Ventura, Monterey, or Big Sur] or Windows 11/Windows 10 (Version 1809 or newer).
- Processor: 64-bit CPU (Intel or AMD); 4 cores or greater; 1.7 Ghz or greater / Intel-based Mac devices or Apple Silicon ones (Fusion 360 still has to be emulated through Rosetta 2)
- Memory: 4 GB of RAM (integrated graphics recommended)
- Graphics Card: DirectX11 (Direct3D 10.1 or greater) Dedicated GPU with 1 GB or more of VRAM (integrated graphics not recommended)
- Disk Space: 8.5 GB of storage

This subject does not offer any credits for University Entrance Literacy

Prerequisites: 8 credits from Year 11 DGT required or HOF approval

Internal Credits	22	External Credits	3	Total	25
-------------------------	-----------	-------------------------	----------	--------------	-----------

EOTC Days	0	Estimated Trip Costs	\$0	Costs	\$25
------------------	----------	-----------------------------	------------	--------------	-------------

[Return to Contents](#)

L2 - Technology – Hard Materials Technology (HMT)

Year 12 Hard Materials Technology (HMT) programme offers the students an opportunity to grow their woodworking skills. This is intended to provide students with a well-balance4d, practically orientated course that develops lifelong skills, stimulates self-esteem and confidence and generates a sense of pride in paying attention to detail. Because we offer NCEA Achievement standards, there is a 50% paper-based theoretical component.

This subject does not offer any credits for University Entrance Literacy

Prerequisites: 8 credits from Year 11 preferred or HOF approval

Internal Credits	18	External Credits	0	Total	18
-------------------------	-----------	-------------------------	----------	--------------	-----------

EOTC Days	0	Estimated Trip Costs	\$0	Costs	\$135
------------------	----------	-----------------------------	------------	--------------	--------------

L2 – Technology – Hospitality (HOS)

Level 2 Hospitality consists of 7 Unit Standards which builds on prior Hospitality Studies. Students will be:

- Applying good food safety practices
- Preparing and presenting fruits, vegetables, salads and sandwiches for service
- Cook food by roasting and frying
- Cook food by baking in the commercial kitchen
- Students will also be baking cakes, sponges and scones as in the hospitality industry
- Learning about commercial espresso coffee equipment
- Preparing espresso beverages

This subject does not offer any credits for University Entrance Literacy

Prerequisites: Year 11 Hospitality - 8 credits preferred or HOF approval

Internal Credits	18	External Credits	0	Total	18
-------------------------	-----------	-------------------------	----------	--------------	-----------

EOTC Days	0	Estimated Trip Costs	\$0	Costs	\$275
------------------	----------	-----------------------------	------------	--------------	--------------

[Return to Contents](#)

L2 – Travel and Tourism (TOU)

Level 2 Travel and Tourism covers NZQA travel unit standards. Throughout the course students will be investigating New Zealand and World Tourism destinations. Additionally, students will gain tourism calculation, time management and comprehension skills.

There is an opportunity to apply in class learning with an optional trip to International Travel College and AJ Hockett. This involves a bungy and a bridge climb which would cost approximately \$320.

This subject does not offer any credits for University Entrance Literacy.

Prerequisites: None

Internal Credits	19	External Credits	0	Total	19
-------------------------	-----------	-------------------------	----------	--------------	-----------

EOTC Days	0	Estimated Trip Costs	\$320	Costs	\$100
------------------	----------	-----------------------------	--------------	--------------	--------------

[Return to Contents](#)

Level 3 Courses - 2025

National Certificate of Educational Achievement – Level 3

60 credits of achievement or unit standards must be gained.

New Zealand Scholarship

A New Zealand Scholarship award can be achieved through an additional examination. Scholarship is aimed at extending very able students. Enrolment in Scholarship subjects is by consultation with the Head of Senior School. Students should indicate their intention by the end of Term 1 2025.

The compulsory subject: Biblical Studies or Religious Studies.

Optional Subjects

Most students take a course of FIVE subjects (plus Biblical Studies) in Year 13

Select SIX from list below – in order of preference with the sixth being a **BACKUP**:

Accounting#	Hard Materials Technology#
Adventure Based Leadership	History#
Business Studies#	Hospitality
Biology#	Media Studies#
Calculus#	Music#
Chemistry#	Physical Education Studies#
Dance#	Physics#
Digital Technology#	Spanish#
Design and Visual Communications Technology#	Statistics#
Drama#	Travel and Tourism
Earth and Space Science#	Visual Art – Design#
Economics#	Visual Art – Painting#
English#	Visual Art – Printmaking#
Gateway	
Geography#	

Indicates University Approved Subjects

PREREQUISITES - For entry requirements into Level 3 subjects refer to prerequisites and information of the individual subjects.

UNIVERSITY REQUIREMENTS - Students hoping to pursue a university course after Year 13 should check on prerequisites for entry into courses at the university of their choice.

EXCEPTIONS BY APPLICATION

At KingsWay we want to see students in programmes that meet their learning needs. See the section on page 11 for permissible exceptions to the criteria above and the application process required for these.

[Return to Contents](#)

L3 – Art – Design (ARD)

Level 3 Design students have the choice to take either a Graphic Novel, Promotional or animation approach. Students will analyse the work and techniques of at least 3 designers. They will write a proposal around which to build a folio on. They will show an influence of their chosen designers while creating their own body of work. It is essential that students are proficient at working digitally to systematically generate, develop and clarify their ideas.

This subject does not offer any credits for University Entrance Literacy.

Prerequisites: Level 2 ART or HOF approval

University Approved: Yes

Internal Credits	8	External Credits	14	Total	22
-------------------------	----------	-------------------------	-----------	--------------	-----------

EOTC Days	0	Estimated Trip Costs	\$0	Costs	\$58
------------------	----------	-----------------------------	------------	--------------	-------------

L3 – Art – Paint (ART)

Level 3 Paint students will analyse the work and techniques of at least 3 artists. They will choose a theme from which they will write a proposal and build a folio of paintings. Students will show an influence of these artists while creating their own body of work. They will use mainly paint to systematically generate, develop and clarify their ideas.

This subject does not offer any credits for University Entrance Literacy.

Prerequisites: Level 2 ART or HOF approval

University Approved: Yes

Internal Credits	8	External Credits	14	Total	22
-------------------------	----------	-------------------------	-----------	--------------	-----------

EOTC Days	0	Estimated Trip Costs	\$0	Costs	\$58
------------------	----------	-----------------------------	------------	--------------	-------------

[Return to Contents](#)

L3 – Art – Print (ARP)

Level 3 Print students will analyse the work and techniques of at least 3 printers. They will choose a theme from which they will write a proposal and build a folio of prints. They will show an influence of these printers, while creating their own body of work. Students will use mainly print to systematically generate, develop and clarify their ideas.

This subject does not offer any credits for University Entrance Literacy.

Prerequisites: Level 2 ART or HOF approval

University Approved: Yes

Internal Credits	8	External Credits	14	Total	22
-------------------------	----------	-------------------------	-----------	--------------	-----------

EOTC Days	0	Estimated Trip Costs	\$0	Costs	\$58
------------------	----------	-----------------------------	------------	--------------	-------------

L3 - Biblical Studies (BST)

Year 12/13 Biblical Studies is designed to develop a foundation of Biblical knowledge that equips students to think and evaluate from a Christian perspective. Students are encouraged to “own” their faith and be ready to celebrate, critique and confront the world in which they live. Topics include:

- Ethics
- Christianity and World Religions
- Acts and the New Testament Church
- The new rules for love, sex and dating

This subject does not offer any credits for University Entrance Literacy.

Prerequisites: None

University Approved: No

Internal Credits	0	External Credits	0	Total	0
-------------------------	----------	-------------------------	----------	--------------	----------

EOTC Days	0	Estimated Trip Costs	\$0	Costs	\$0
------------------	----------	-----------------------------	------------	--------------	------------

[Return to Contents](#)

L3 – Accounting (ACC)

Level 3 Accounting introduces partnerships and companies. Students will gain an understanding of end of year financial statements and their interpretation, in order to give advice to both internal and external users. It will provide a very solid foundation for further studies in Business at University, where Accounting is a compulsory component.

This subject does not offer any credits for University Entrance Literacy.

Prerequisites: 12 Level 2 Accounting credits or HOF approval

University Approved: Yes

Internal Credits	8	External Credits	9	Total	17
-------------------------	----------	-------------------------	----------	--------------	-----------

EOTC Days	0	Estimated Trip Costs	\$0	Costs	\$30
------------------	----------	-----------------------------	------------	--------------	-------------

L3 – Business Studies (BUS)

This course offers students the unique opportunity of participating in the Young Enterprise Programme. As well as being worth 9 NCEA credits, the YES programme is “hands-on” with students setting up their own company, creating a product/service and selling in order to earn real profits. It is a great opportunity to learn and develop invaluable skills such as teamwork, communication and managing a process. All teams have the opportunity to enter the regional and national awards and competitions to compete for cash prizes. In addition to the YES programme, students will study marketing theory and complete a marketing plan, as well as looking at the financial and non-financial factors that affect business decisions.

This subject carries ten reading credits and four writing credits for University Entrance Literacy.

Prerequisites: None but the course is most suited to students with high levels of self-motivation

University Approved: Yes

Internal Credits	15	External Credits	4	Total	19
-------------------------	-----------	-------------------------	----------	--------------	-----------

EOTC Days	2	Estimated Trip Costs	\$15	Costs	\$80
------------------	----------	-----------------------------	-------------	--------------	-------------

[Return to Contents](#)

L3 – Economics (ECO)

A key question at Level 3 is the role of the government when the market is seen to have “failed” to provide the best outcomes for society. There is also a comparison of the way in which different businesses compete with others and an analysis of how pricing decisions can be made to maximise revenue and profits for a business. A review of the key macroeconomic variables such as exchange rates and inflation will give students an excellent grounding for university study in Economics, as well as an appreciation for the way in which the New Zealand economy functions.

This subject carries eighteen reading credits and four writing credits for University Entrance Literacy

Prerequisites: Eight credits in Level 2 Economics Standards

University Approved: Yes

Internal Credits	10	External Credits	8	Total	18
-------------------------	-----------	-------------------------	----------	--------------	-----------

EOTC Days	0	Estimated Trip Costs	\$0	Costs	\$50
------------------	----------	-----------------------------	------------	--------------	-------------

L3 – Dance (DAN)

Level 3 Dance is the culmination of all dance skills learnt and workshopped over the three years. This course will challenge and inspire students to step into new realms of performance skill. The final choreography piece they create is an amalgamation of all creative processes tried and ‘trialled previously’. These students perform together at our annual Arts Week and present their final pieces onstage as an acknowledgement of their time in dance at KingsWay.

This subject carries four literacy credits.

Prerequisites: L2 DANCE or HOF approval

University Approved: Yes

Internal Credits	18-22	External Credits	4	Total	22-26
-------------------------	--------------	-------------------------	----------	--------------	--------------

EOTC Days	1	Estimated Trip Costs	\$80	Costs	\$95
------------------	----------	-----------------------------	-------------	--------------	-------------

[Return to Contents](#)

L3 – Drama (DRA)

Level 3 Drama provides students with the chance to truly become their own actors. This course stretches students to do the learning themselves; there is a far greater emphasis on personal development as an actor with the introduction of a research assessment on dramatic theorists, which challenges students to apply those theories to their own practice. The expectation of students' performance is significantly higher than Level 2 as they prepare authentic, challenging pieces based on historical events and heroes, bringing them to life in a fresh way.

This subject carries up to eight reading credits and up to four writing credits for University Entrance Literacy.

Prerequisites: L2 DRAMA or HOF approval

University Approved: Yes

Internal Credits	17	External Credits	4	Total	21
-------------------------	-----------	-------------------------	----------	--------------	-----------

EOTC Days	1	Estimated Trip Costs	\$95	Costs	\$80
------------------	----------	-----------------------------	-------------	--------------	-------------

L3 – English (ENG)

This University Approved Course allows you to gain UE Literacy credits. It is focused on extending students who have achieved Level Two English. Novels, Shakespearean texts and films of critical acclaim are used for both internal and external assessment. The focus will be on critically analysing different texts, both literary and visual, crafting and presenting a coherent oral text, developing an informed understanding of literature and responding critically to significant aspects of visual texts through close viewing.

This subject carries eight reading credits and eight writing credits for University Entrance Literacy.

Prerequisites: L2 English credits (4 must be from an external standard)

University Approved: Yes

Internal Credits	10	External Credits	8	Total	18
-------------------------	-----------	-------------------------	----------	--------------	-----------

EOTC Days	0	Estimated Trip Costs	\$0	Costs	\$0
------------------	----------	-----------------------------	------------	--------------	------------

[Return to Contents](#)

L3 – Geography (GEO)

Students will learn how interacting processes shape natural and cultural environments and understand how people's diverse values and perceptions influence environmental, social and economic decisions. The course includes a 2-day camp to Rotorua and trips to Muriwai Beach and Stanmore Bay Beach to conduct coastal research. Topics include Contemporary Global Issues, Tourism Development and Geographic Research.

This subject carries nine reading credits and four writing or reading credits for University Entrance Literacy.

Prerequisites: None

University Approved: Yes

Internal Credits	14	External Credits	4	Total	18
-------------------------	-----------	-------------------------	----------	--------------	-----------

EOTC Days	3	Estimated Trip Costs	\$360	Costs	\$0
------------------	----------	-----------------------------	--------------	--------------	------------

L3 – History (HIS)

Level 3 History presents four standards in a wide range of contexts including early New Zealand History and World War II, which are still hotly debated by historians, and significant for New Zealanders. The course includes a three-day field trip to the Bay of Islands.

This subject carries fifteen reading credits and six reading or writing credits for University Entrance Literacy.

Prerequisites: Level 1 or 2 History is preferred or 14 credits or more in other literacy heavy subject e.g. English

University Approved: Yes

Internal Credits	15	External Credits	6	Total	21
-------------------------	-----------	-------------------------	----------	--------------	-----------

EOTC Days	3	Estimated Trip Costs	\$300	Costs	\$0
------------------	----------	-----------------------------	--------------	--------------	------------

[Return to Contents](#)

L3 - Mathematics – Calculus (MAC)

This course prepares students for further studies involving Mathematics. The course builds on foundational concepts of calculus introduced at Level 2. It aims to provide students with a deeper understanding of calculus principles and techniques, focusing on advanced differentiation, integration, trigonometry, conic sections, and complex algebra. There are two internally assessed standards and three externally assessed standards.

This subject does not offer any credits for University Entrance Literacy.

Prerequisites: 12 achieved credits at Level 2 Calculus. Students who have not met these prerequisites can apply to the HOF for discretionary entry into this course.

University Approved: Yes

Internal Credits	7	External Credits	17	Total	24
-------------------------	----------	-------------------------	-----------	--------------	-----------

EOTC Days	0	Estimated Trip Costs	\$0	Costs	\$24
------------------	----------	-----------------------------	------------	--------------	-------------

L3 - Mathematics – Statistics (MAS)

This course allows students to fulfil the requirements for a university approved subject in either Level 3 Statistics or in Level 3 Mathematics. It is designed to deepen students' understanding of statistical concepts and develop their statistical literacy. The course focuses on advanced statistical techniques, data analysis and interpretation. There are three internally assessed reports on time series analysis, inferences, and bivariate data and one standard on probability in the course which allows students to gain subject endorsement.

This subject does not offer any credits for University Entrance Literacy.

Prerequisites: 12 achieved credits at Level 2 Calculus or Level 2 Statistics. Students who have not met these prerequisites can apply to the HOF for discretionary entry into this course.

University Approved: Yes

Internal Credits	14	External Credits	4	Total	18
-------------------------	-----------	-------------------------	----------	--------------	-----------

EOTC Days	0	Estimated Trip Costs	\$0	Costs	\$8
------------------	----------	-----------------------------	------------	--------------	------------

[Return to Contents](#)

L3 – Media Studies (MST)

Level 3 Media Studies focuses on evaluating media in society and helping students understand their own relationship with the media to make them ‘critical, active, informed and responsible citizens’ (NZC). The focus shifts from exploring and examining media texts, to evaluating and critiquing the place of media in society. To do this, students study groups of texts that make up a genre, learn the skills of close reading to be able to analyse and evaluate the content, and explore, develop and communicate ideas through the development of their skills in the use of media technology to produce and craft their own short film. Reliable attendance and an enthusiasm and willingness to work in small groups is essential. If a student is picking this up at Level 3 (with no prior experience of the Level 2 course), it is expected that they will put in the extra time necessary to catch up on the media terminology and editing skills.

This subject carries four reading credits and seven writing credits for University Entrance Literacy.

Prerequisites: None

University Approved: Yes

Internal Credits	16	External Credits	4	Total	20
-------------------------	-----------	-------------------------	----------	--------------	-----------

EOTC Days	2	Estimated Trip Costs	\$150	Costs	\$50
------------------	----------	-----------------------------	--------------	--------------	-------------

L3 – Music (MUS)

Level 3 Music creates opportunities for students to build on their individual musical strengths. They develop their own learning programme in the areas of Composition, Song Writing, Performance, Theory Skills and Musicology or a selection from each area. Students will be given authentic opportunities to deepen their understanding and further develop their abilities including an opportunity to perform at Arts Week, and experience in other external events.

This subject carries up to 10 reading credits and four writing credits for University Entrance Literacy.

Prerequisites: L2 Music or HOF approval. Instrumental and / or vocal ability or experience required.

University Approved: Yes

Internal Credits	14-20	External Credits	4-8	Total	22
-------------------------	--------------	-------------------------	------------	--------------	-----------

EOTC Days	1	Estimated Trip Costs	\$50	Costs	\$90
------------------	----------	-----------------------------	-------------	--------------	-------------

[Return to Contents](#)

L3 – Pathways – Gateway (GAT)

The Gateway programme is designed to equip Year 13 students with transferable skills and industry exposure, preparing them to be work-ready. Gateway provides valuable insights into students' skills, strengths, values, and personality, helping them explore preferred pathways beyond school.

Programme Highlights:

- **Personalised Learning:** Students develop individualised learning plans tailored to their interests, strengths, and career aspirations.
- **Self Awareness:** Students explore through Gallup Strength Finders the strengths and talents that God has given them and how to action them effectively in their lives. This reinforces their identity as his unique and purposeful creation, enriches their sense of belonging and provides insight into what he may be calling them forward into.
- **Workshops and Practical Applications:** Through workshops and practical applications, students acquire employability and transferable life skills and earn a certificate to enhance their CVs.
- **Industry-Relevant Courses:** Students participate in work-ready courses and short courses relevant to their chosen industries.
- **Structured Workplace Learning:** Students engage in formal workplace arrangements, gaining hands-on experience and employability skills, enabling them to make informed career decisions.
- **Accredited Learning:** Some work placements offer the opportunity to be assessed against unit standards on the New Zealand Qualifications Framework (NZQF) and integrated into the students' learning programme.

Entry Requirements:

- **Year 13 Students:** Open entry
- **Interview Process:** Students must undergo an interview to assess their suitability and commitment to the programme.
- **Work Placement Arrangements:** Students and their whanau are expected to help arrange and support the requirements to fulfill the work placement.
- **Discretionary Entry:** Students who have completed Gateway in Year 12 may be considered for a second year of Gateway on a discretionary basis.

Qualifications Earned:

- Earn a minimum of 15 NCEA Level 3 credits.

Cost:

- Free of charge, funded through the Tertiary Education Commission.

[Return to Contents](#)

L3 - Physical Education – Adventure Based Learning (ABL)

This course is designed for students who want outdoors experiences that will enhance personal and social development in a variety of pursuits, and foster leadership skills. It covers the main themes of leadership, first aid, risk management, fitness principles and adventure activities.

The course requires commitment and organization, with the opportunity to learn and practice new skills. Units contain both theoretical and practical components and will be assessed in class and out in the field. Topics are covered in an order that makes best use of weather and other conditions during the year but, as with all outdoor activities, an element of flexibility is required. The course will build upon existing foundations in the outdoors and foster enjoyment, appreciation and gratitude for God's creation.

This subject does not offer any credits for University Entrance Literacy.

Prerequisites: Approval by HOF PE required due to number limits in this class (logistical reasons).

University Approved: No

Internal Credits	20	External Credits	0	Total	20
-------------------------	-----------	-------------------------	----------	--------------	-----------

EOTC Days	7	Estimated Trip Costs	\$375	Costs	\$30
------------------	----------	-----------------------------	--------------	--------------	-------------

L3 - Physical Education Studies (PES)

Physical Education students will use knowledge gained from Year 12 Physical Education to research and critically analyse sports issues as well as develop performance in sport. This course includes approximately 60% theory work and 40% practical work throughout the year. Topics covered include leadership, biomechanics, training principles, biomechanics and contemporary sport issues such as commercialisation.

This subject carries eight reading credits for University Entrance Literacy

Prerequisites: Approval required from HOF if Level 2PES has not been completed

University Approved: Yes

Internal Credits	19	External Credits	0	Total	19
-------------------------	-----------	-------------------------	----------	--------------	-----------

EOTC Days	0	Estimated Trip Costs	\$100	Costs	\$25
------------------	----------	-----------------------------	--------------	--------------	-------------

[Return to Contents](#)

L3 – Science – Biology (BIO)

The course is divided into three key modules:

- Human Biology – This looks at the biological systems within the human body that help maintain a stable internal environment and investigates our ability to manipulate genetic material by looking at a human case study, as well as an individual practical investigation into human physiology.
- Plant and Animal Responses – This investigates the responses of plants and animals to their external environment and includes the study of the fascinating world of animal behaviour.
- Evolution – a detailed study of the theory of Evolution, the evidence and fallacies (from a Biblical Worldview).

Course fees are for the Education Perfect online resource (paid only once if taking Chemistry, Biology or Physics at Level 3).

This subject carries fifteen reading credits and nine writing credits for University Entrance Literacy.

Prerequisites: Minimum grade of Achieved (or better) in Biology 2.5 Genetic Variation and Biology 2.7 Gene Expression plus One Internal. HOF discretion.

University Approved: Yes

Internal Credits	10	External Credits	9	Total	19
-------------------------	-----------	-------------------------	----------	--------------	-----------

EOTC Days	1	Estimated Trip Costs	\$50	Costs	\$30
------------------	----------	-----------------------------	-------------	--------------	-------------

L3 – Science – Chemistry (CHE)

Level 3 Chemistry builds on knowledge and skills gained in Level 2 Chemistry. There is a large proportion of practical work built into the course. Students will demonstrate an awareness of the relationships between experimental data and theoretical interpretation. They will analyse and process data and information, consolidate technical skills and acquire a deeper understanding of the core concepts of Chemistry. The topics covered will include Oxidation-Reduction reactions, Thermochemistry and Particles, Organic Chemistry, Spectroscopy and Aqueous systems. Course fees are for the Education Perfect online resource (paid only once if taking Chemistry, Biology or Physics at Level 3).

This subject does not offer any credits for University Entrance Literacy.

Prerequisites: Minimum grade of Achieved in two External and one Internal assessment. HOF discretion.

University Approved: Yes

Internal Credits	6	External Credits	15	Total	21
-------------------------	----------	-------------------------	-----------	--------------	-----------

EOTC Days	0	Estimated Trip Costs	\$0	Costs	\$30
------------------	----------	-----------------------------	------------	--------------	-------------

L3 - Science – Earth and Space Science (ESS)

Level 3 Earth and Space Science explores the interconnections between the land, ocean, atmosphere, and life of our planet. These include the cycles of water, carbon, rock, and other materials that continuously shape, influence, and sustain Earth and its inhabitants. ESS investigates the major ocean currents that flow past New Zealand and the impact these and other factors have on our weather and climate. The Earth is dynamically linked with the solar system and the wider universe. ESS investigates the structure and composition of these systems and develops understanding of the vast distances and times involved. Course fees are for the Education Perfect online resource (paid only once if taking Chemistry, Biology or Physics at Level 3).

This subject carries four writing credits through the external and twelve reading credits through internals.

Prerequisites: None

University Approved: Yes

Internal Credits	16	External Credits	4	Total	20
-------------------------	-----------	-------------------------	----------	--------------	-----------

EOTC Days	1	Estimated Trip Costs	\$60	Costs	\$30
------------------	----------	-----------------------------	-------------	--------------	-------------

L3 – Science – Physics (PHY)

Level 3 Physics extends the concepts learnt in the Year 12 course. Newton's Laws are applied in two dimensional translational motion, and extended into rotational and oscillatory motions. The behaviour of a variety of wave phenomena are explored, including the doppler effect, beats and interference. Quantum physics of the atom is introduced, along with a deeper understanding of Nuclear fission and fusion and their importance. The Electromagnetism topic explores the nature and generation of current in both DC and AC circuits, Kirchhoff's rules are introduced and specific investigation is undertaken into the effects of inductive and capacitive elements in both AC and DC circuits. Course fees are for the Education Perfect online resource (paid only once if taking Chemistry, Biology or Physics at Level 3).

This subject carries three reading credits for University Entrance Literacy.

Prerequisites: Minimum grade of Achieved (or better) in Physics 2.4 Mechanics and Physics 2.6 Electromagnetism plus One Internal. HOF discretion.

University Approved: Yes

Internal Credits	6	External Credits	16	Total	22
-------------------------	----------	-------------------------	-----------	--------------	-----------

EOTC Days	1	Estimated Trip Costs	\$70	Costs	\$30
------------------	----------	-----------------------------	-------------	--------------	-------------

[Return to Contents](#)

L3 – Spanish (SPA)

Level 3 Spanish focuses on the ability to interact and analyse spoken and written texts in Spanish, exploring and justifying varied ideas and perspectives. Global issues, current events and history are explored from a biblical perspective within the following topics: caretaking the earth, embracing cultural differences, pursuing peace and culture shapers in the Spanish speaking world. Students will also have the opportunity to experience Spanish/Latin American food, attend film festivals, and interact with Spanish speaking visitors.

This subject does not offer any credits for University Entrance Literacy.

Prerequisites: 10 credits or more achieved in Level 2 Spanish or an equivalent level of spoken and written Spanish

University Approved: Yes

Internal Credits	8	External Credits	10	Total	18
-------------------------	----------	-------------------------	-----------	--------------	-----------

EOTC Days	0.5	Estimated Trip Costs	\$20	Costs	\$60
------------------	------------	-----------------------------	-------------	--------------	-------------

[Return to Contents](#)

L3 - Technology – Design and Visual Communication (DVC)

The Year 13 DVC programme follows the NZQA Design and Visual communication technology achievement standard course. This is intended to provide secondary students with Graphic and Technology skills which involve design and the mastering of Computer Aided applications such as Fusion 360. The Level 3 course enables students to attain Level 3 Achievement Standards in the domain of Technology.

The system requirements for DVC are as follows:

- Operating System: macOS [Ventura, Monterey, or Big Sur] or Windows 11/Windows 10 (Version 1809 or newer).
- Processor: 64-bit CPU (Intel or AMD); 4 cores or greater; 1.7 Ghz or greater / Intel-based Mac devices or Apple Silicon ones (Fusion 360 still has to be emulated through Rosetta 2)
- Memory: 4 GB of RAM (integrated graphics recommended)
- Graphics Card: DirectX11 (Direct3D 10.1 or greater) Dedicated GPU with 1 GB or more of VRAM (integrated graphics not recommended)
- Disk Space: 8.5 GB of storage

This subject does not offer any credits for University Entrance Literacy.

Prerequisites: L2 DVC preferred but not essential. Approval of HOF/TIC required if subject not studied before.

University Approved: Yes

Internal Credits	12	External Credits	6	Total	18
-------------------------	-----------	-------------------------	----------	--------------	-----------

EOTC Days	0	Estimated Trip Costs	\$50	Costs	\$65
------------------	----------	-----------------------------	-------------	--------------	-------------

[Return to Contents](#)

L3 - Technology – Digital Technology (DGT)

This course focuses on the processes and development of digital outcomes with a particular emphasis on project management using agile development. Students will undertake the creation of a digital media produced, such as a multimedia website or a video production, with the choice of pairing this with an optional standard where a client and stakeholders are worked with in order to refine the Brief for their outcome. Students will also undertake the development of a computer program such as an app or any other program that solves a problem. There is a total of 20 credits available at Level 3 Digital Technologies with 16 of these forming the core course.

The system requirements for DGT are as follows:

- Operating System: macOS [Ventura, Monterey, or Big Sur] or Windows 11/Windows 10 (Version 1809 or newer).
- Processor: 64-bit CPU (Intel or AMD); 4 cores or greater; 1.7 Ghz or greater / Intel-based Mac devices or Apple Silicon ones (Fusion 360 still has to be emulated through Rosetta 2)
- Memory: 4 GB of RAM (integrated graphics recommended)
- Graphics Card: DirectX11 (Direct3D 10.1 or greater) Dedicated GPU with 1 GB or more of VRAM (integrated graphics not recommended)
- Disk Space: 8.5 GB of storage

This subject does not carry any credits for University Entrance Literacy.

Prerequisites: Level 2 DGT 14 credits required.

University Approved: Yes

Internal Credits	20	External Credits	0	Total	20
-------------------------	-----------	-------------------------	----------	--------------	-----------

EOTC Days	1	Estimated Trip Costs	\$25	Costs	\$25
------------------	----------	-----------------------------	-------------	--------------	-------------

[Return to Contents](#)

L3 - Technology – Hard Materials (HMT)

The Level 3 Hard Materials Technology programme follows the NZQA construction and mechanical technologies and generic achievement standard course. This is intended to provide secondary students with a well-balanced, practically orientated course that develops lifelong skills, stimulates self-esteem and confidence, and generates a sense of pride in paying attention to detail. There is a 50% theoretical component which does involve paperwork.

The Level 3 HMT course enables students to achieve Level 3 Achievement Standards in the domain of Technology.

This subject does not carry any credits for University Entrance Literacy.

Prerequisites: 14 credits Level 2 HMT preferred or HOF approval

University Approved: Yes

Internal Credits	16	External Credits	0	Total	16
-------------------------	-----------	-------------------------	----------	--------------	-----------

EOTC Days	0	Estimated Trip Costs	\$0	Costs	\$145
------------------	----------	-----------------------------	------------	--------------	--------------

[Return to Contents](#)

L3 - Technology – Hospitality (HOS)

Level 3 Hospitality consists of 4 Unit Standards which further develop students' abilities in the Hospitality industry.

- Students will be developing their knowledge about a wide range of culinary products and their preparation methods.
- Students will be preparing and presenting complex sandwiches in a commercial kitchen.
- Students will be preparing and cooking preserves, chutneys and pickles in the commercial kitchen.
- Students will also be learning the art of becoming a barista and the knowledge behind coffee production.
- Students will prepare and bake classic cakes, pasta and egg dishes in the commercial kitchen.

This subject does not offer any credits for University Entrance Literacy

Prerequisites: If a student is new to L3HOS (the student has not taken L2HOS the year before), it is a pre-requisite for all students to do a mandatory Level 2 standard – US 167 (Practice food safety methods in a food business), in order to be able to cook in a commercial kitchen. This will take place in February 2025 and has a cost of \$15.00pp US 167 carries an additional 4 credits.

University Approved: No

Internal Credits	18	External Credits	0	Total	18
-------------------------	-----------	-------------------------	----------	--------------	-----------

EOTC Days	0	Estimated Trip Costs	\$0	Costs	\$285
------------------	----------	-----------------------------	------------	--------------	--------------

L3 – Travel and Tourism (TOU)

Level 3 Travel and Tourism covers NZQA travel unit standards. Students will undertake an in-depth investigation of Australia, NZ and the South Pacific as tourist destinations. An Adventure Tourism Trip with an outdoor activity will be included as part of the course. There is an opportunity to apply in class learning with an optional trip to International Travel College and AJ Hockett. This involves a bungy and a bridge climb which would cost approximately \$320.

This subject does not offer any credits for University Entrance Literacy.

Prerequisites: None

University Approved: No

Internal Credits	18	External Credits	0	Total	18
-------------------------	-----------	-------------------------	----------	--------------	-----------

EOTC Days	0	Estimated Trip Costs	\$0	Costs	\$100
------------------	----------	-----------------------------	------------	--------------	--------------

[Return to Contents](#)

Faculty Pathways

Arts Faculty

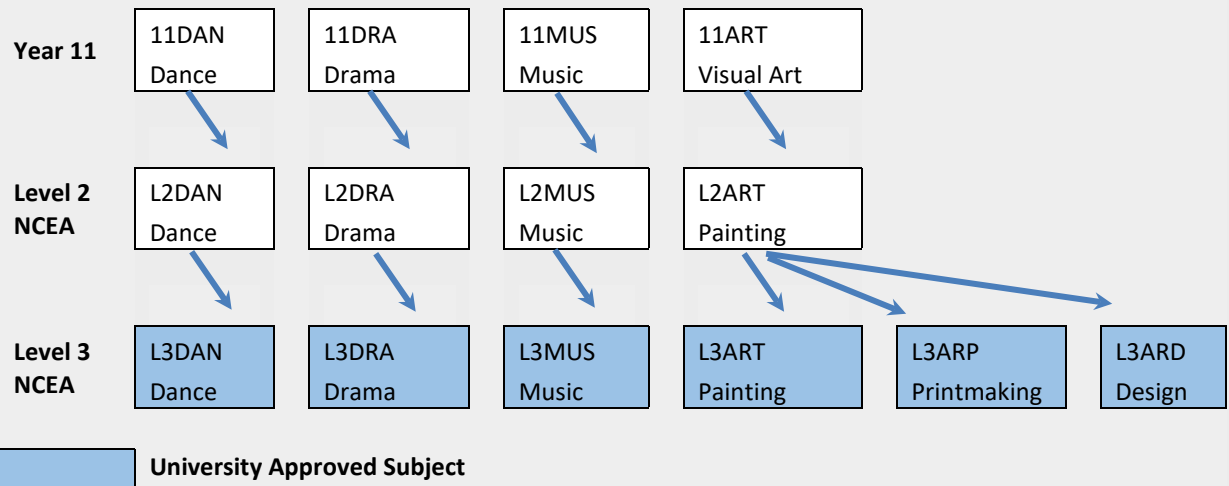

Biblical Studies Faculty

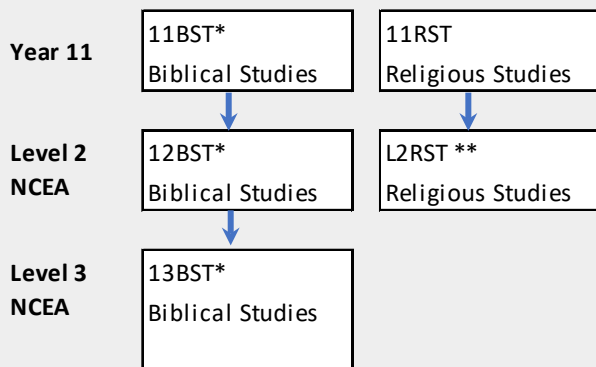

* Not an NCEA Subject

** Subject to course viability

[Return to Contents](#)

Business Faculty

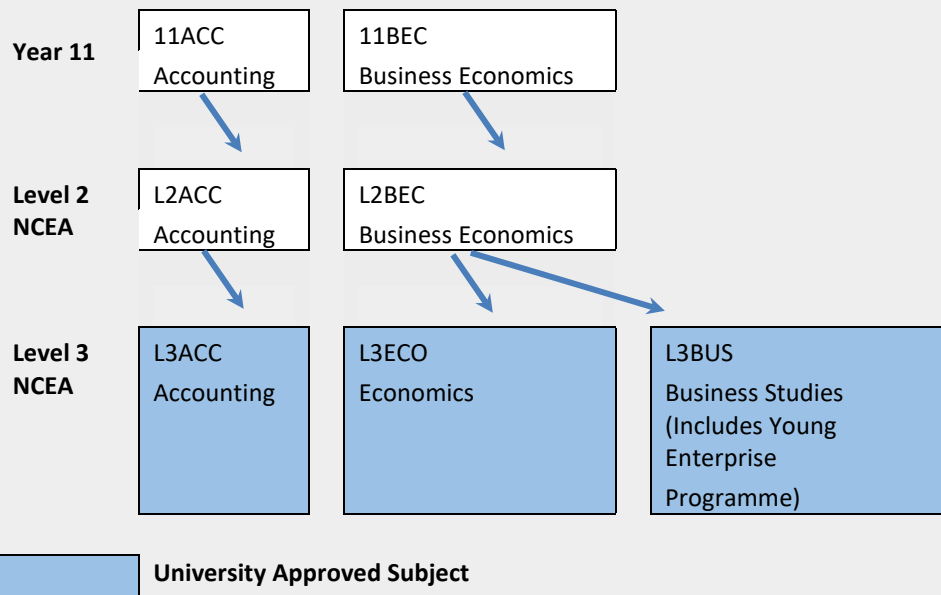

English and Languages Faculty

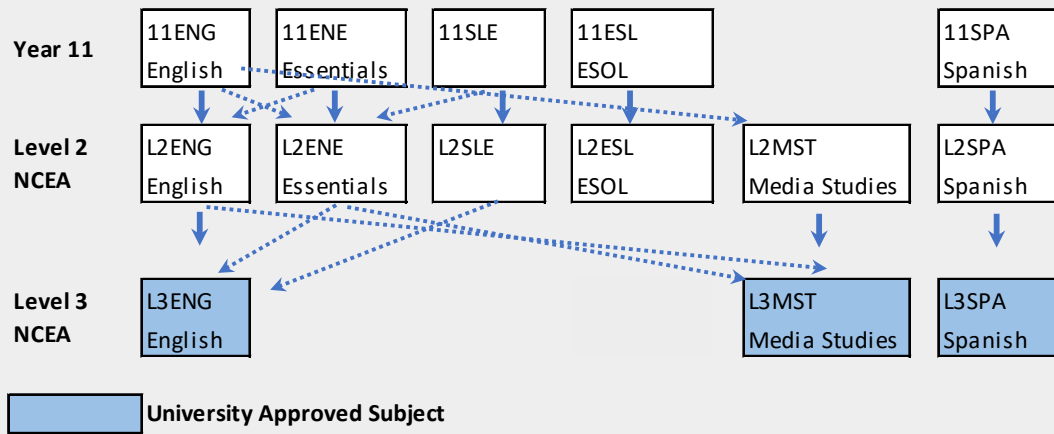

[Return to Contents](#)

Mathematics Faculty

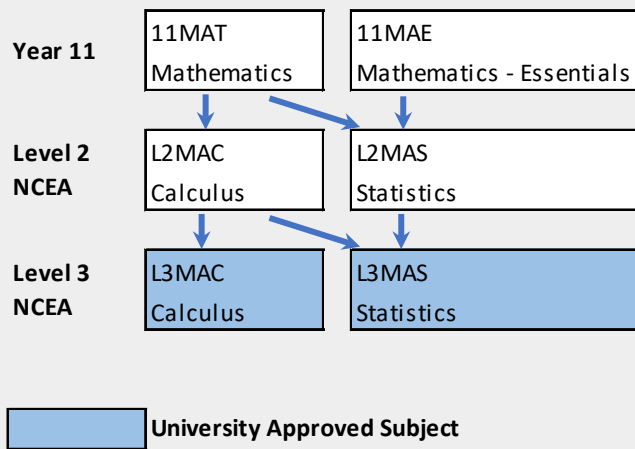

[Return to Contents](#)

Physical Education and Hauora Faculty

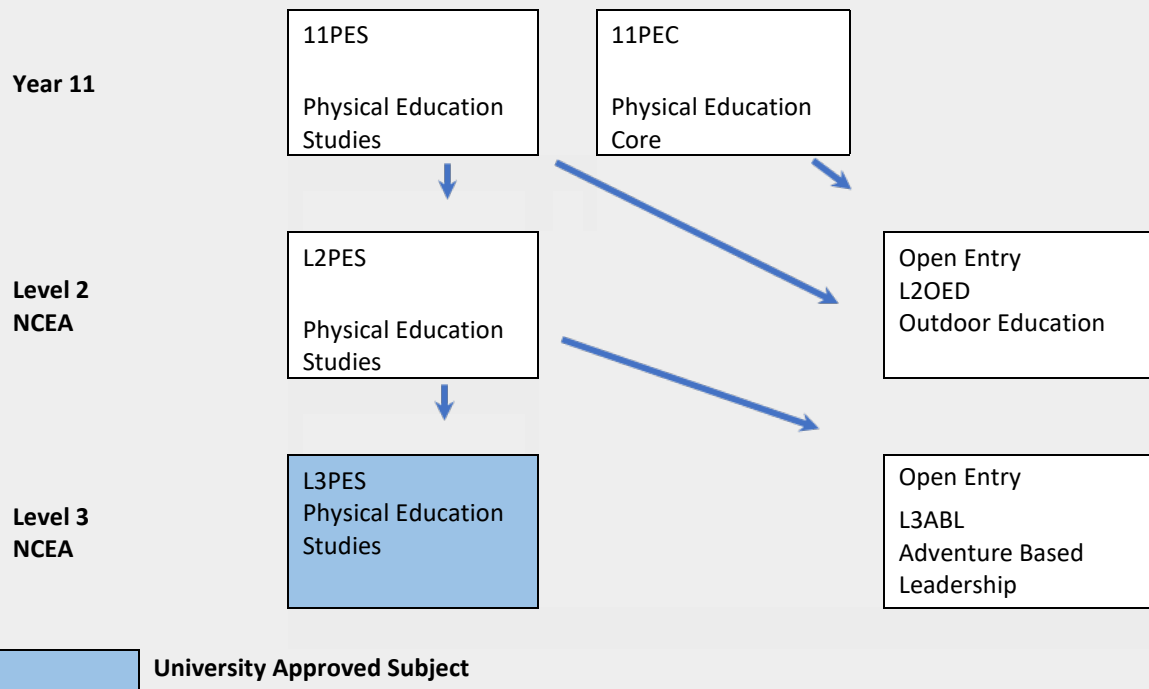

[Return to Contents](#)

Science Faculty

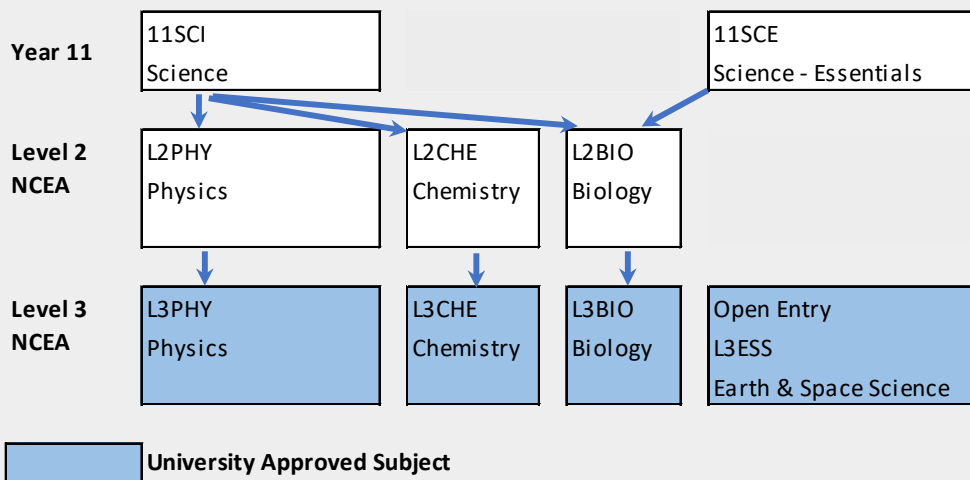

Social Sciences Faculty

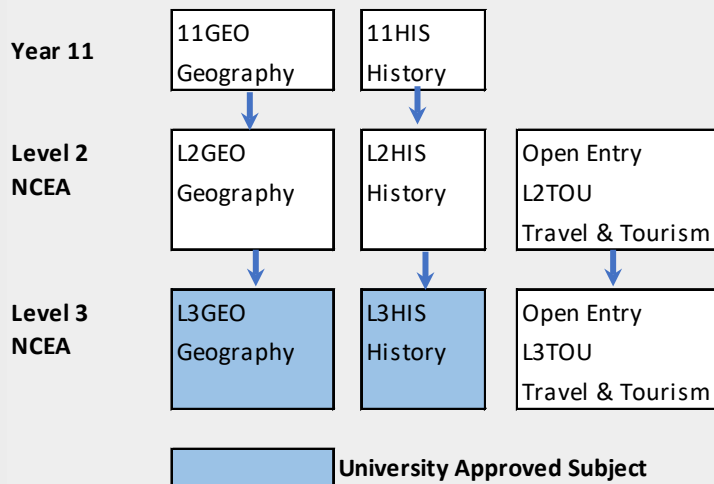

[Return to Contents](#)

Technology Faculty

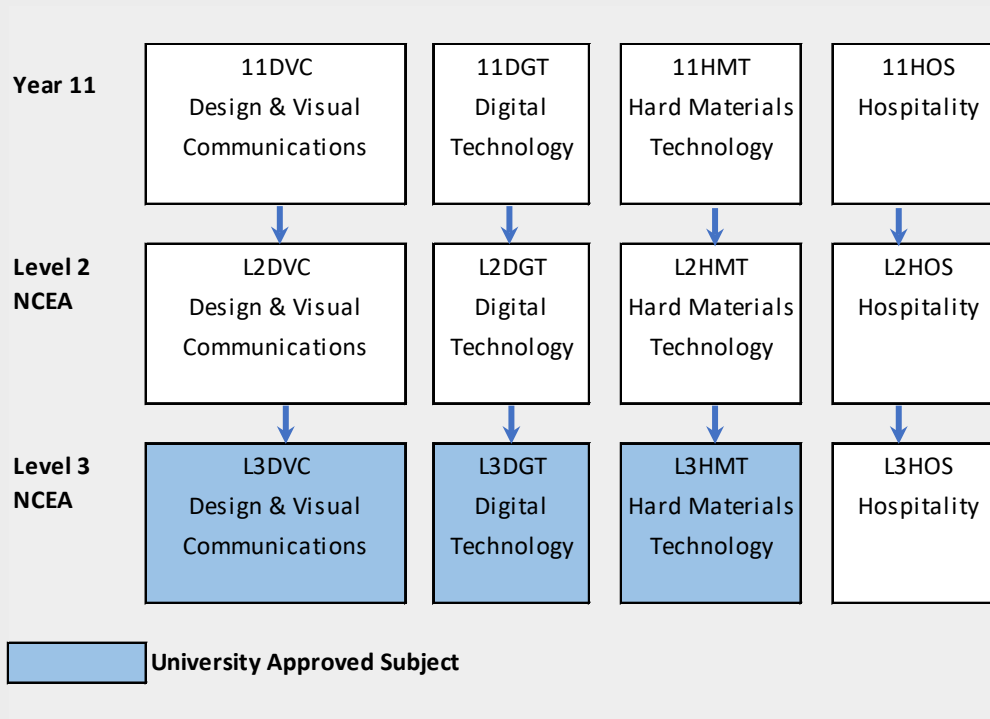

[Return to Contents](#)

A Guide to NCEA Assessment Procedures

Course Outlines

At the beginning of each year course outlines will be published. The course outline includes:

- Course title
- Standards offered (title, number, version)
- Number of credits
- Internally or externally assessed
- Probable assessment dates
- Reassessment opportunities

Handing in Work and Extensions

All work must be handed in on time. In class assessments will be due on a Monday at 8.45 am whenever possible, unless otherwise stated by the teacher.

Extensions to the due date will only be granted by the Principals Nominee through formal application. Forms are available on the school website. Applications must be submitted at least five school days before the assessment due date. [Click here](#) for the NCEA Extension Application

Assessments will not be accepted for marking after other marked work has been sighted by students.

If your absence is unexpected, such as an illness, an extension application must be made as soon as possible.

In the case of an extension for illness, students should do everything possible to obtain and submit a doctor's certificate for the period affected.

School sanctioned trips, as well as trips with provincial and national teams need to be applied for at least five days before assessment date, but preferably as soon as possible.

An NCEA assessment will always take priority over other in-school or out-of-school activities, for example, STAR course attendance will not be approved if dates clash with internal assessments. Where possible, school trips and activities will not occur on assessment dates.

Any family holidays or personal time off are not acceptable reasons for extension or reassessment.

Late work will not be accepted by your teacher unless the above process has been completed.

Assessment Opportunities

A variety of methods are used across the different learning areas to collect evidence for assessment purposes. In some courses there may be a second assessment opportunity in some standards. This will be at the discretion of the Head of Faculty and will be stated in the course outline.

Resubmission

Resubmission opportunities may be offered when a student has shown understanding at a particular grade level but has a minor error that can easily be identified by the student without assistance, which prevents them from achieving that grade. This is solely at the discretion of the teacher, not the student or parent. Resubmission cannot occur if the class has received feedback from marked work or marked work has been sighted and can only occur if the student is close to achieving but has received 'Not Achieved' in their first attempt. There are no longer any resubmissions to move from Achieved to Merit or Merit to Excellence.

Reassessment

In some courses a second assessment opportunity is available for internally assessed standards. This will be stated on the course outline. Further teaching and learning must have occurred before a reassessment. All students entered for the standard will be offered the reassessment opportunity. The reassessment will be a different task. Students will be awarded the higher of their two grades. No reassessment opportunity is available for external achievement standards.

Appeals Procedure

If the student thinks that an assessment has been incorrectly marked, he/she can discuss this with the teacher. This must occur within five days of the students receiving the marked work.

If the student does not agree with the way their work was marked, he/she may appeal. An appeal form must be completed within two school days and handed to the Principal's Nominee. Appeal forms are available on the school website. The Principal's Nominee will arrange for your work to be remarked and you will be notified of the result. [Click here](#) for the NCEA Appeal Application Form.

Authenticity

All work should be the student's own. In all instances where work is completed outside of the classroom, students are required to sign an authenticity declaration to state the work handed in is their own. [Click here](#) for the Student Authenticity Agreement.

In order to ensure that work is authentic, teachers may:

- ask students to complete tasks in class
- collect work at the end of each lesson and return it for the next lesson
- ask students to hand in all draft material
- expect students to meet checkpoints before final deadlines
- discuss ideas and findings with students

Breaches of Assessment Conditions

A breach includes the submission of a piece of work that is not original (not a student's own work).

This includes:

- Plagiarism. This is material which is copied or closely paraphrased from someone else's work without acknowledging the source of that material. It includes all published and unpublished work, material on the internet and the work of other students and staff.
- Undue assistance from family, friends, a tutor or a reader-writer
- Copying or submitting all or part of another student's work
- Allowing another student to use or copy your work
- Using written or recorded material in a closed book assessment
- Getting another student to sit an assessment for you
- Using unauthorised calculators, electronic spell checkers or language dictionaries in assessments

Process:

- The teacher identifies the possibility that a breach has occurred and discusses this with the student
- If the teacher suspects that a breach has occurred, the HOF will investigate further and contact the parents
- If the breach is likely, the HOF liaises with the Principal's Nominee
- If the breach is confirmed the student will receive Not Achieved for that standard
- If another student has been involved in the breach that person will also be penalised
- The Principal's Nominee notifies the Head of School and relevant Dean

- Students who breach assessment conditions in externally assessed standards are referred to New Zealand Qualifications Authority
- The teacher liaises with the Principal's Nominee

Assessment data sent to NZQA

Teachers will ask students to check and sign their results for each standard following the return of their work. Internally assessed results are sent to NZQA monthly. Students may check their results online.

Privacy

All assessment information is stored electronically. It is not available to unauthorised people. Information is used only for reporting and NZQA purposes. Students may view their own data through their individual login on the NZQA website.

Appeal of External Assessment Results

There are two types of appeal.

1. Reviews:
Students may request a review of external assessment material if they consider a processing error has been made.
2. Reconsiderations:
Students may apply for reconsideration of a standard if they believe that their work has not been assessed correctly and they wish to have it re-marked.

Derived Grade Results

Students will complete Derived Grades practise examinations before the external assessments. In the unlikely event that a student is unable to sit an external assessment or a student's performance is impaired, they may be able to apply for a derived grade based upon these previous examination results and other aspects of completed coursework.

Derived grades will only be granted as a result of a circumstance that occurred no more than one month before the start of examinations. Situations gaining approval include serious illness and family bereavement.

An applicant for a derived grade must:

- complete the NZQA application form and submit it to the school by the closing date
- supply a copy of their admission slip with the application
- supply appropriate medical or documented evidence

Special Assistance

Candidates with permanent or long-term conditions or learning difficulties which they believe will significantly impair their performance in assessments may apply to the NZQA for special assessment conditions such as an extra time allowance or the use of a reader or writer. More detailed information is available from the Director of Learning Support : director.learning.support@kingsway.school.nz

If you have any questions, please contact Mr Daniel Bennett (Head of Senior School)
daniel.bennett@kingsway.school.nz or email the Principal's Nominee,
principalsnominee@kingsway.school.nz

[Return to Contents](#)